

# MITSUBISHI

## 三菱工業用ミシン部品カタログ

## Industrial Sewing Machine Parts Catalog

Model PLK-E03BT

目次	CONTENTS	Page
A 本体構成	Construction .....	1
B 本体関係 (1)	Arm bed & it's accessories (1) .....	2
C 本体関係 (2)	Arm bed & it's accessories (2) .....	4
D 縫い機構 (1)	Sewing mechanism (1) .....	6
E 縫い機構 (2)	Sewing mechanism (2) .....	8
F X-Yテーブル機構 (1)	X-Y table mechanism (1) .....	10
G X-Yテーブル機構 (2)	X-Y table mechanism (2) .....	12
H 押え上げ駆動機構	Clamp foot lifter mechanism .....	14
J 押え機構	Work holder mechanism .....	16
K 糸切り機構	Thread trimming mechanism .....	18
L ワイパー機構	Wiper mechanism .....	20
M 給油機構	Oil lubrication mechanism .....	22
N 配線検出器関係	Cable component & Detector mechanism .....	24
P テーブル関係	Table & Stand .....	26
Q 付属品 (1)	Accessories (1) .....	28
R 付属品 (2)	Accessories (2) .....	30
S オプションパーツ	Option parts .....	32
索引	Index .....	34

# 部品コードの採番形式

## MITSUBISHI SPARE PARTS No. Designation system

### 1. 部品コードについて CONCERNING PARTS CODE.

部品をご注文される場合は、部品コードをお知らせください。

Please inform the part number, when these parts are ordered.

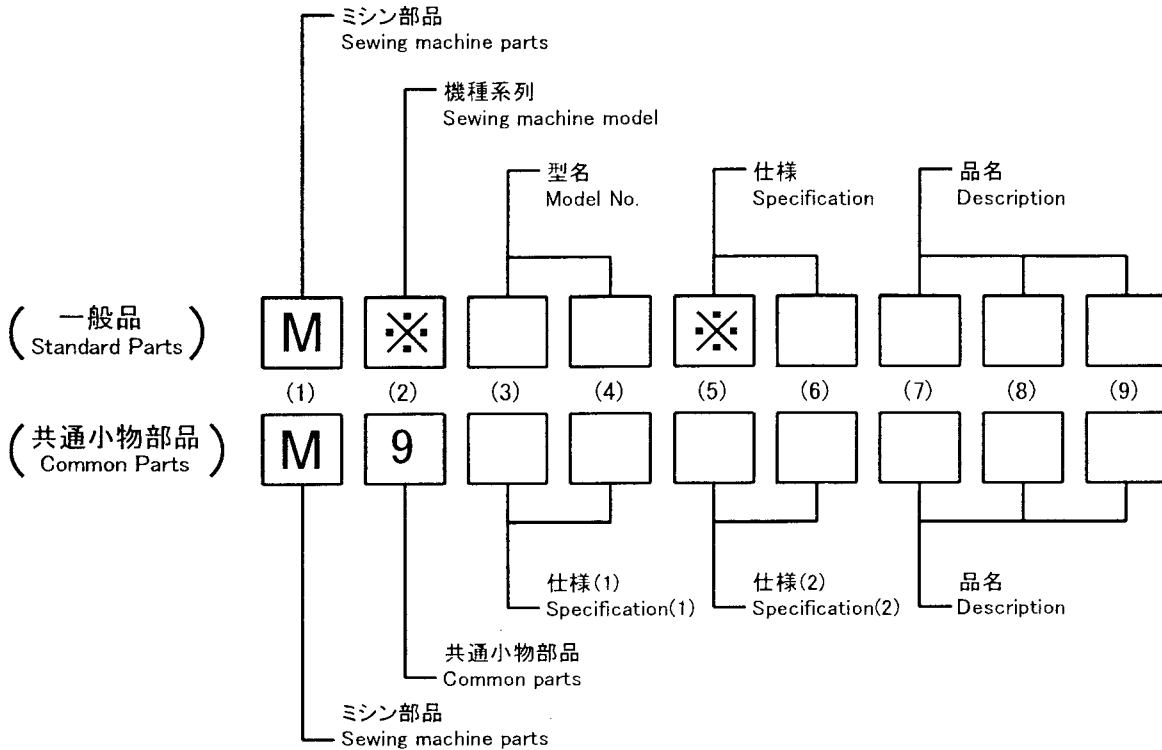

### 【 例 Example 】

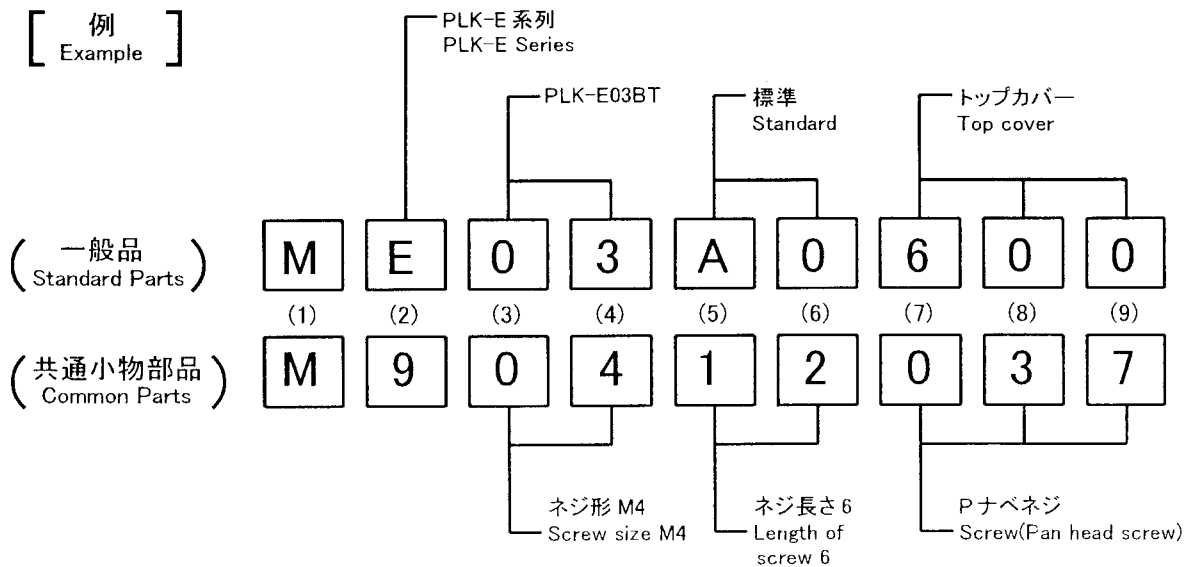

### 2. 変更マークについて CONCERNING MODIFICATION MARK.

変更マーク欄に\*記号のある部品は、形状、寸法などの変更履歴がありますので、ご注文の際にはご使用の製品の製造番号と合わせてご覧ください。

The parts marked with \* in the modification column has been changed the shape or size etc. So when these modified parts are ordered please inform the serial number of the sewing machine.

注：一般品についての機種型名は、その部品が最初に使用された機種型名を示します。

従って長期にわたる場合は、機種の改廃が行われるため、当初の機種以外の機種で使用されている場合があります。

Sewing machine Models, of Standard Parts are Indicated model of these parts are registered firstly. Parts are used for not only the indicated model, but also another models, in reason of New development, improvement after.

**A** 全体構成  
CONSTRUCTION

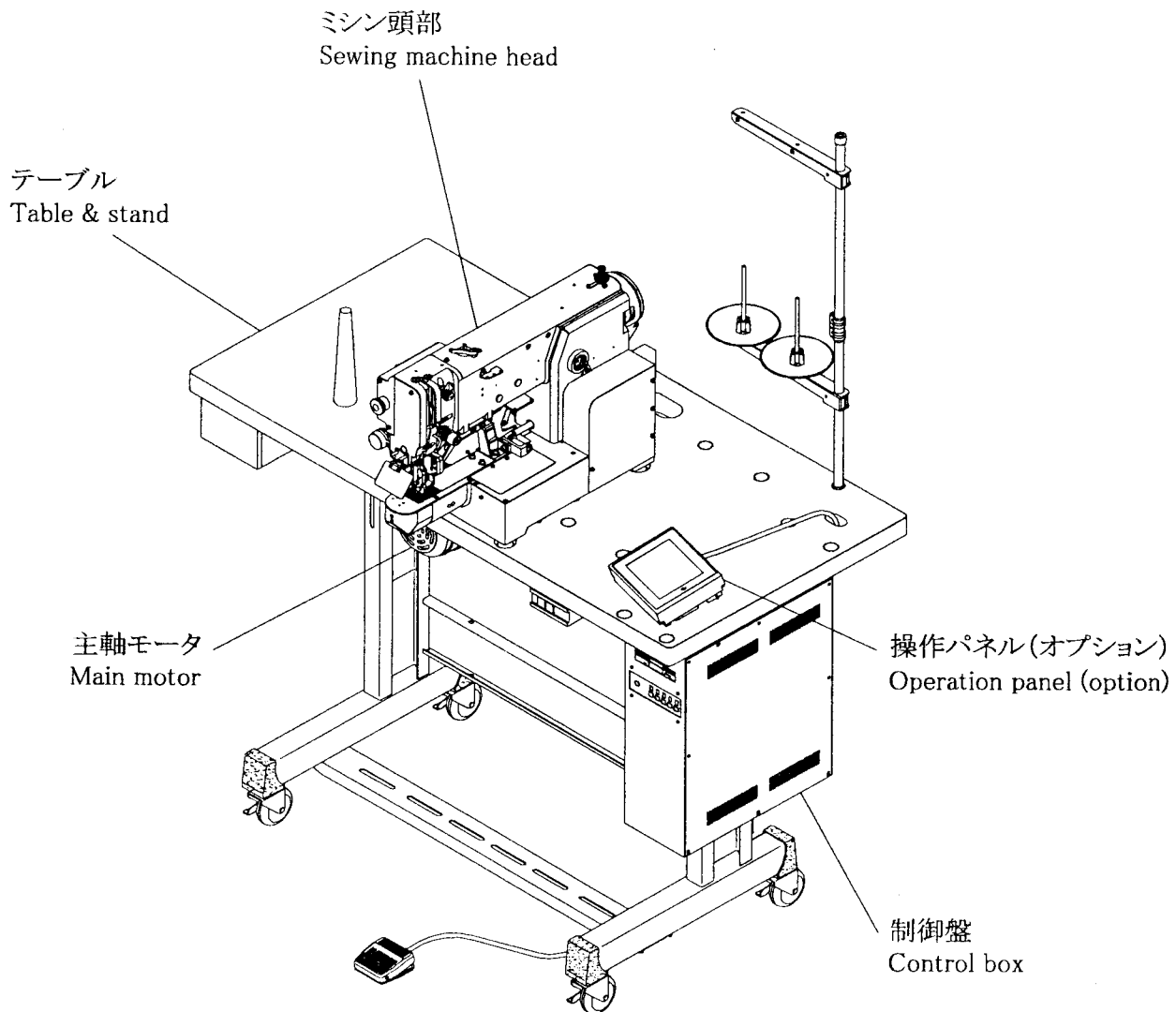

注1：モータ部分は三菱リミサーボX部品カタログを参照ください。

注2：Fig.No.の採番していない部品は単体で支給することは出来ません。Setにて支給いたします。

Remarks 1) Concerning about the motor parts please refer to the parts catalog of MITSUBISHI LIMISERVO X.

Remarks 2) The parts which Fig.No. are not marked are not available individually. It can be supplied with the whole component.

**B** 本体関係(1)  
ARM BED & IT'S ACCESSORIES(1)

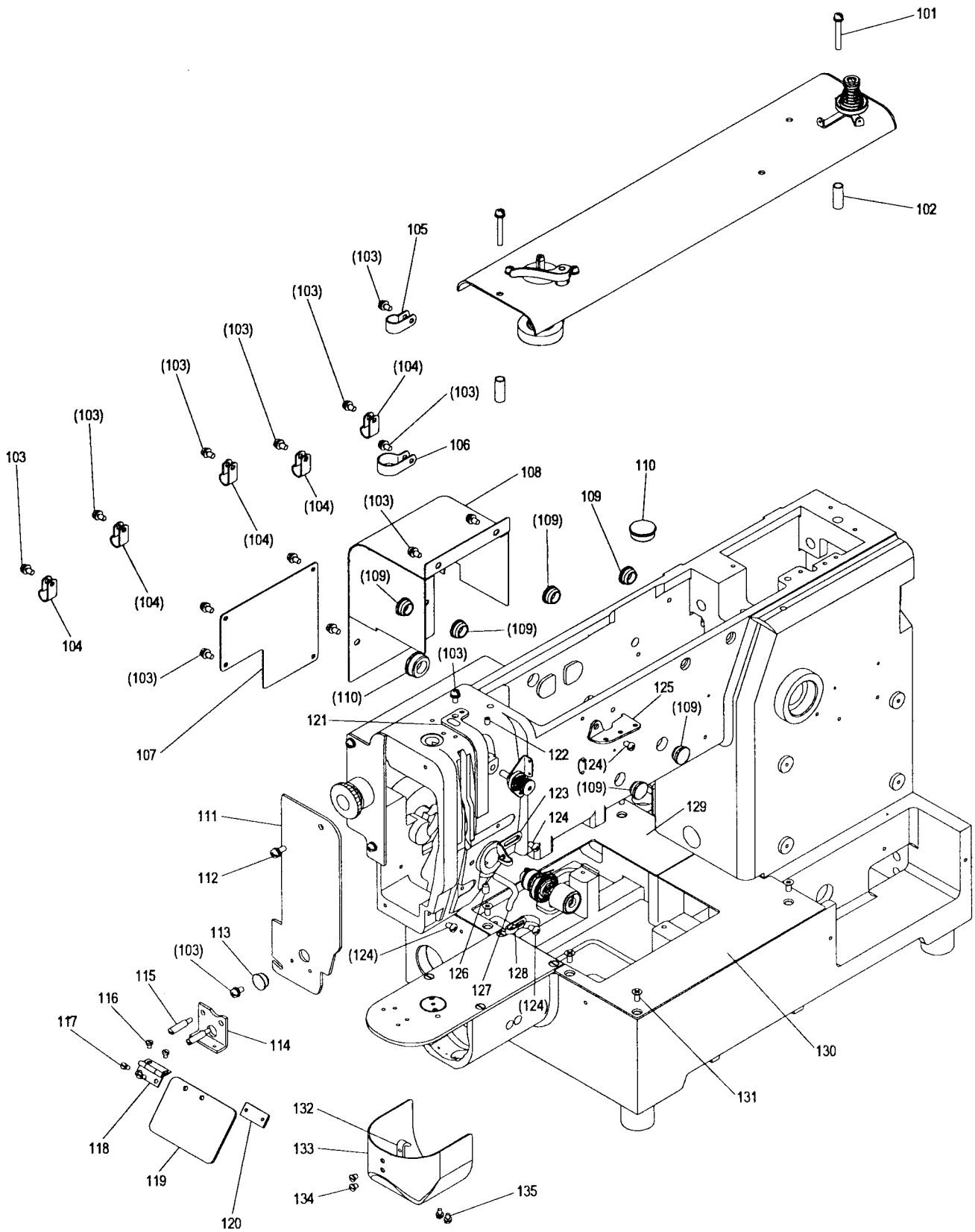

From the library of: Diamond Needle Corp

## [B] 本体関係(1)

## ARM BED &amp; IT'S ACCESSORIES (1)

Fig no.	変更 Mod.	部品コード Parts no.	品名	Description	数量 Amt. Req.
B 101		M91276004	SW-PWﾌﾟﾗﾏｲﾅﾍﾞﾈｼﾞ M4X30	Screw M4X30	2
B 102		MB62A0352	ｽﾍﾞｰｻ 1382312-60200	Spacer	2
B 103		M91054004	SW-PWﾌﾟﾗﾏｲﾅﾍﾞﾈｼﾞ M4X8	Screw M4X8	17
B 104		MN60A0620	ﾅｲﾛﾝｸﾘｯﾌﾟ AB-5N	Nylon clip AB-5N	5
B 105		M94007099	ﾅｲﾛﾝｸﾘｯﾌﾟ AB-6N	Nylon clip AB-6N	1
B 106		MB60A2620	ﾅｲﾛﾝｸﾘｯﾌﾟ AB-10N	Nylon clip AB-10N	1
B 107		ME10A0742	ﾌﾀ	Cover	1
B 108		ME03A0849	ﾓｰﾀｶﾊﾞｰ	Motor cover	1
B 109		M91304080	ｺﾞﾑｾﾝ φ13	Rubber plug φ13	6
B 110		M91910080	ｺﾞﾑｾﾝ φ19	Rubber plug φ19	2
B 111		ME03A0830	ﾏﾝｲﾀ	Face cover	1
B 112		M91056004	SW-PWﾌﾟﾗﾏｲﾅﾍﾞﾈｼﾞ M4X10	Screw M4X10	1
B 113		M91180080	ｺﾞﾑｾﾝ φ11.8	Rubber plug φ11.8	1
B 114		MS08A0601	ｱｲｶﾞｰﾄﾞﾄﾘｯｹｲﾀ	Eye guard bracket	1
B 115		ML10A0889	ﾋﾝﾈｼﾞ 1/8(44)	Pin screw 1/8(44)	2
B 116		M90804002	ﾋﾗﾈｼﾞ 1/8(44)X3.8	Screw 1/8(44)X3.8	2
B 117		M90806002	ﾋﾗﾈｼﾞ 1/8(44)X6	Screw 1/8(44)X6	2
B 118		MS01A1739	ﾋﾝｼﾞ	Hinge	1
B 119		MS08A0160	ｱｲｶﾞｰﾄﾞ	Eye guard	1
B 120		MS01A0477	ｽﾄｯﾊﾟ	Adapter	1
B 121		MA20A0584	ﾃﾞﾝﾋﾝｶﾊﾞｰ	Thread take-up lever guard	1
B 122		M91053020	ﾛｯｶｸﾞｱﾅｯｷﾄﾒｼﾞ M4X6	Screw M4X6	1
B 123		MG43A0181	ｲﾄｱﾝﾅｲ	Thread guide	1
B 124		M91011004	ﾌﾟﾗﾏｲﾅﾍﾞﾈｼﾞ M4X6	Screw M4X6	4
B 125		MF36A1180	ｲﾄｱﾝﾅｲ	Thread guide	1
B 126		M95004020	ﾛｯｶｸﾞｱﾅｯｷﾄﾒｼﾞ M5X8	Screw M5X8	1
B 127		MF70A1180	ｲﾄｱﾝﾅｲ	Thread guide	1
B 128		MF10A0181	ｲﾄｱﾝﾅｲ	Thread guide	1
B 129		ME03A0339	X ｶﾊﾞｰｲﾀ (L)	X Cover plate (L)	1
B 130		ME03A1339	X ｶﾊﾞｰｲﾀ (R)	X Cover plate (R)	1
B 131		M91400010	Pｻﾗﾈｼﾞ M4X8	Screw M4X8	6
B 132		MS01A0361	ｶｹｶﾞﾈ	Latch	1
B 133		MB60E6339	ｼﾘﾝﾀｰｶﾊﾞｰ	Cylinder cover	1
B 134		M90906003	ﾏﾙﾋﾗﾈｼﾞ 9/64(40)X3.2	Screw 9/64(40)X3.2	2
B 135		M90859004	SW-PWﾌﾟﾗﾏｲﾅﾍﾞﾈｼﾞ M3X6	Screw M3X6	2

**C 本体関係(2)**  
**ARM BED & IT'S ACCESSORIES(2)**

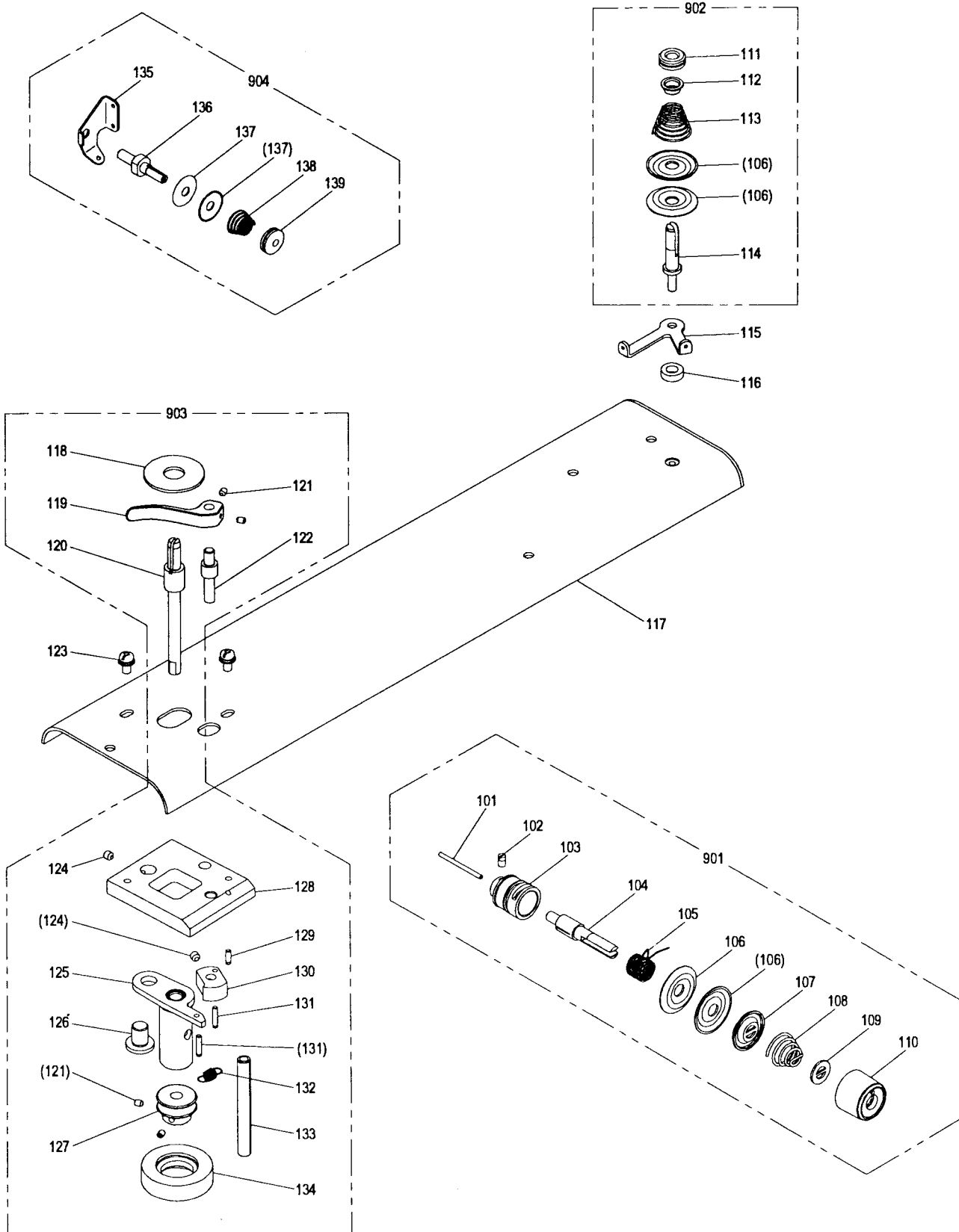

## [C] 本体関係(2)

## ARM BED &amp; IT'S ACCESSORIES (2)

Fig no.	変更 Mod.	部品コード Parts no.	部品名	Description	数量 Amt. Req.
C 101		M90204060	ピン	Pin	1
C 102		M90901002	ヒラネジ 9/64(40)X4	Screw 9/64(40)X4	1
C 103		MF10A0709	ブッシュ	Regulator casing	1
C 104		MF10A0553	チョウシボウ	Thread tension stud	1
C 105		MF10A0187	イトリハネ	Thread take-up spring	1
C 106		MF10A0555	チョウシガラ	Thread tension discs	4
C 107		MM11A0556	チョウシガラオサエ	Disc retaining plate	1
C 108		MM52A1245	インスイハネ	Thread tension spring	1
C 109		MT60A0802	マワリドメ	Thumb nut revolution stopper	1
C 110		M91605045	ツaminaット	Thumb nut	1
C 111		M91602046	ツaminaット	Thumb nut	1
C 112		MM11A0702	ハネアンナイ	Spring guide	1
C 113		MM11A0245	インスイハネ	Thread tension spring	1
C 114		MS14A0553	チョウシボウ	Thread tension stud	1
C 115		MS14A0180	イトアンナイ	Thread guide	1
C 116		MG75A1476	スペーサー	Spacer	1
C 117		ME03A0600	トップカバー	Top cover	1
C 118		MA20A0476	スペーサー	Spacer	1
C 119		MA20A1950	レバー	Lever	1
C 120		MA04A1530	ダンツキジク D	Driven shaft	1
C 121		M91057020	ロックアナツキメネジ M3X4	Screw M3X4	4
C 122		MA04A2530	ダンツキジク	Shaft	1
C 123		M91054004	SW-PWプラマイナハネジ M4X8	Screw M4X8	2
C 124		M91055020	ロックアナツキメネジ M4X4	Screw M4X4	2
C 125		MB60E0950	レバークミタテ	Lever	1
C 126		M99006063	ピン	Pin	1
C 127		MA20A0194	イトマキグルマ	Wheel	1
C 128		MB60A1601	トリツケイタ	Bracket	1
C 129		M91004067	ミゾツキピン BXカタ φ2.5X8	Pin φ2.5X8	1
C 130		MS14A0350	カム	Cam	1
C 131		M91005067	ミゾツキピン BXカタ φ2.5X12	Pin φ2.5X12	2
C 132		MS14A0572	ツルマキハネ	Spring	1
C 133		M90601064	スプリングピン φ6X56	Pin φ6X56	1
C 134		MS03A0417	ゴムワ	Tire	1
C 135		MF00A0181	イトアンナイ	Thread guide	1
C 136		MF00A0553	チョウシボウ	Thread tension stud	1
C 137		MF10A1555	チョウシガラ	Thread tension discs	2
C 138		MF36A0245	インスイハネ	Thread tension spring	1
C 139		M91101046	ツaminaット	Thumb nut	1
C 901		MA16E0210	チョウセツキクミタテ	Thread tension Regulator assy	1
C 902		MS14E0180	チョウセツキクミタテ	Thread tension Regulator assy	1
C 903		MB60E0190	イトマキソウチクミタテ	Bobbin winder	1
C 904		MF00E0550	チョウセツキクミタテ	Thread tension Regulator assy	1

**D** 縫い機構(1)  
SEWING MECHANISM(1)

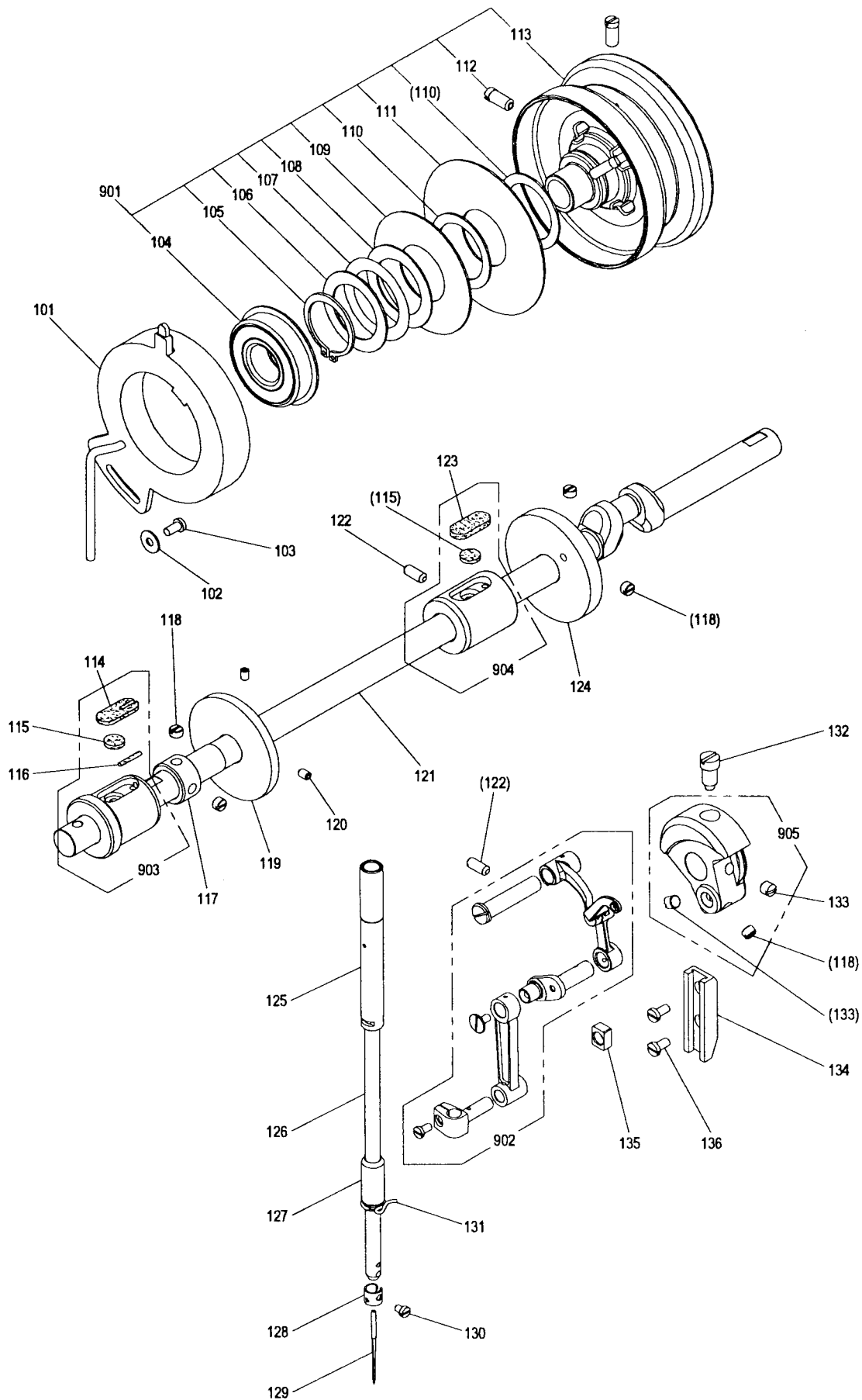

From the library of: Diamond Needle Corp



## [D]縫い機構(1)

## SEWING MECHANISM (1)

Fig no.	変更 Mod.	部品コード Parts no.	品名	Description	数量 <sup>1</sup> Amt. Req.
D 101		MB60A2406	ウワジクケンシュツキ	Detector	1
D 102		M93002050	ザガネ	Washer	1
D 103		M91069004	プラマイナネジ M4X8	Screw M4X8	1
D 104		MN10A1456	ボールベアリング	Ball bearing	1
D 105		M90330065	Cガタメワ 30	C-type retaining ring 30	1
D 106		M93001050	ザガネ	Washer	1
D 107		MF01A0259	ナミザガネ	Wave washer	1
D 108		MF01A1476	スペーサー B	Spacer B	1
D 109		MN72A1694	ハンシャパン F20 (ウワイチ)	Command disk F20 (up)	1
D 110		MF01A0476	スペーサー A	Spacer A	2
D 111		MB60A0694	ハンシャパン K10 (シタイチ)	Command disk K10 (down)	1
D 112		M91520002	ヒラネジ 15/64(28)X12	Screw 15/64(28)X12	2
D 113		MB60E0682	プーリ	Pulley	1
D 114		MG50A0740	フェルト	Felt	1
D 115		MS10A1740	フェルト	Felt	2
D 116		MV88A0740	フェルト	Felt	1
D 117		MF70A0352	カラー	Collar	1
D 118		M91602001	トメネジ 1/4(40)X4	Screw 1/4(40)X4	5
D 119		MS14A0682	イトマキプーリ	Pulley	1
D 120		M91053020	ロックアナツキトメネジ M4X6	Screw M4X6	2
D 121		ME03A0230	ウワジク	Drive shaft	1
D 122		M91221001	トメネジ M5X12	Screw M5X12	2
D 123		MF60A2740	フェルト	Felt	1
D 124		MS01A0350	イトキリカム	Thread trimmer cam	1
D 125		MS01A0663	ハリホウメタル (ウエ)	Needle bar bushing (upper)	1
D 126		MS01A0660	ハリホウ	Needle bar	1
D 127		MG30A0664	ハリホウメタル (シタ)	Needle bar bushing (lower)	1
D 128		MF21D0181	イトアンナイ	Thread guide	1
D 129		MV14A1128	ミンハリ DPX5#16	Needle DPX5#16	1
D 130		M90815002	ヒラネジ 1/8(44)X4.5	Screw 1/8(44)X4.5	1
D 131		MF01A0181	イトアンナイ	Thread guide	1
D 132		M91802006	ヒラネジホウサキ 9/32(28)	Set screw 9/32(28)	1
D 133		M91606001	トメネジ 1/4(40)X6	Screw 1/4(40)X6	2
D 134		MS01A0155	アンナイダイ	Guide	1
D 135		MF10A0325	カクコマ	Square block	1
D 136		M90990002	ヒラネジ M4X8	Screw M4X8	2
D 901		MB60E1682	プーリクミタテ	Pulley assy	1
D 902		MS01E0580	テンピンハリクミタテ	Thread take-up lever assy	1
D 903		MS10A0232	ウワジクメタル(ヒダリ)クミ	Drive shaft bushing L assy	1
D 904		MB60E0234	ウワジクメタル(ナカ)クミ	Drive shaft bushing C assy	1
D 905		MS01A0383	クランククミ	Crank assy	1

E 縫い機構(2)  
SEWING MECHANISM(2)

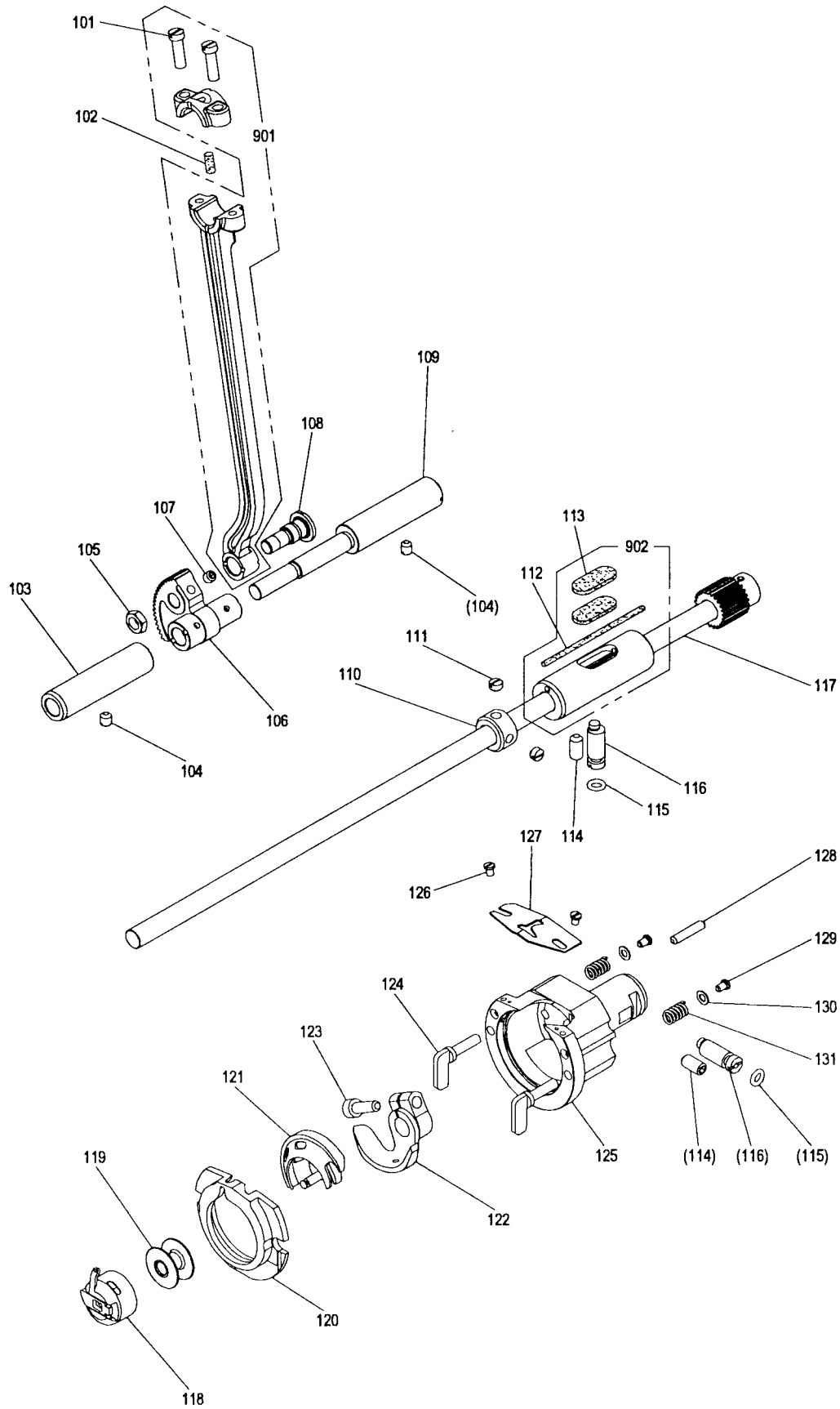

## [E]縫い機構(2)

## SEWING MECHANISM (2)

Fig no.	変更 Mod.	部品コード Parts no.	品名	Description	数量 Amt. Req.
E 101		M91203002	ヒラネジ 3/16(28)X15	Screw 3/16(28)X15	2
E 102		MB60A0740	フェルト	Felt	1
E 103		MS01A0833	メタル	Bushing	1
E 104		M91223001	トメネジ M5X10	Screw M5X10	2
E 105		M91802045	ナット 9/32(28)	Nut 9/32(28)	1
E 106		MS01A0508	セクタハグルマ	Sector gear	1
E 107		M95004021	ロックアナツキトメネジ M5X5	Screw M5X5	1
E 108		M98003015	ヒラネジタツキ 9/32(28)	Screw 9/32(28)	1
E 109		MS01A0891	ヨウトウシク	Rock shaft	1
E 110		MM11A0352	カラー	Collar	1
E 111		M91503001	トメネジ 15/64(28)X4.5	Screw 15/64(28)X4.5	2
E 112		ME10A0148	ヒモ	Oil braid	1
E 113		MA20A0740	フェルト	Felt	2
E 114		M91650020	ロックアナツキトメネジ M6X8	Screw M6X8	2
E 115		M90500085	O リング	O-ring	2
E 116		MS01A0761	ヘンジンシク	Eccentric shaft	2
E 117		ME03E0450	シタシククミ	Hook shaft assy	1
E 118		MS08A0125	ボビンケース	Bobbin case	1
E 119		MS01A0123	ボビン	Bobbin	1
E 120		MS08A0616	ナカガマオサエ	Hook retaine	1
E 121		MS01A0120	ナカガマ	Inner hook	1
E 122		MS01A0611	ドライバ	Hook driver	1
E 123		M95001021	ロックアナツキボルト M5X16	Bolt M5X16	1
E 124		MS09A0950	カマオサエツマミ	Hook clamp	2
E 125		MS01A0121	ソトガマ	Outer hook	1
E 126		M90853002	ヒラネジ 1/8(40)X4	Screw 1/8(40)X4	2
E 127		MS01A0329	カマイトアンナイ	Thread guide	1
E 128		M90001060	ヘイコウピン m6-4X18	Pin m6-4X18	1
E 129		M90802003	マルヒラネジ 1/8(44)X4.5	Screw 1/8(44)X4.5	2
E 130		M93006050	サガネ	Washer	2
E 131		MS01A0572	ツルマキバネ	Spring	2
E 901		MB60E1956	レンゼツカンクミ	Connecting rod assy	1
E 902		ME10E0452	シタシクメタル(ミキ)クミ	Hook shaft bushing (R) assy	1

**F** X-Yテーブル機構(1)  
 X-Y TABLE MECHANISM(1)

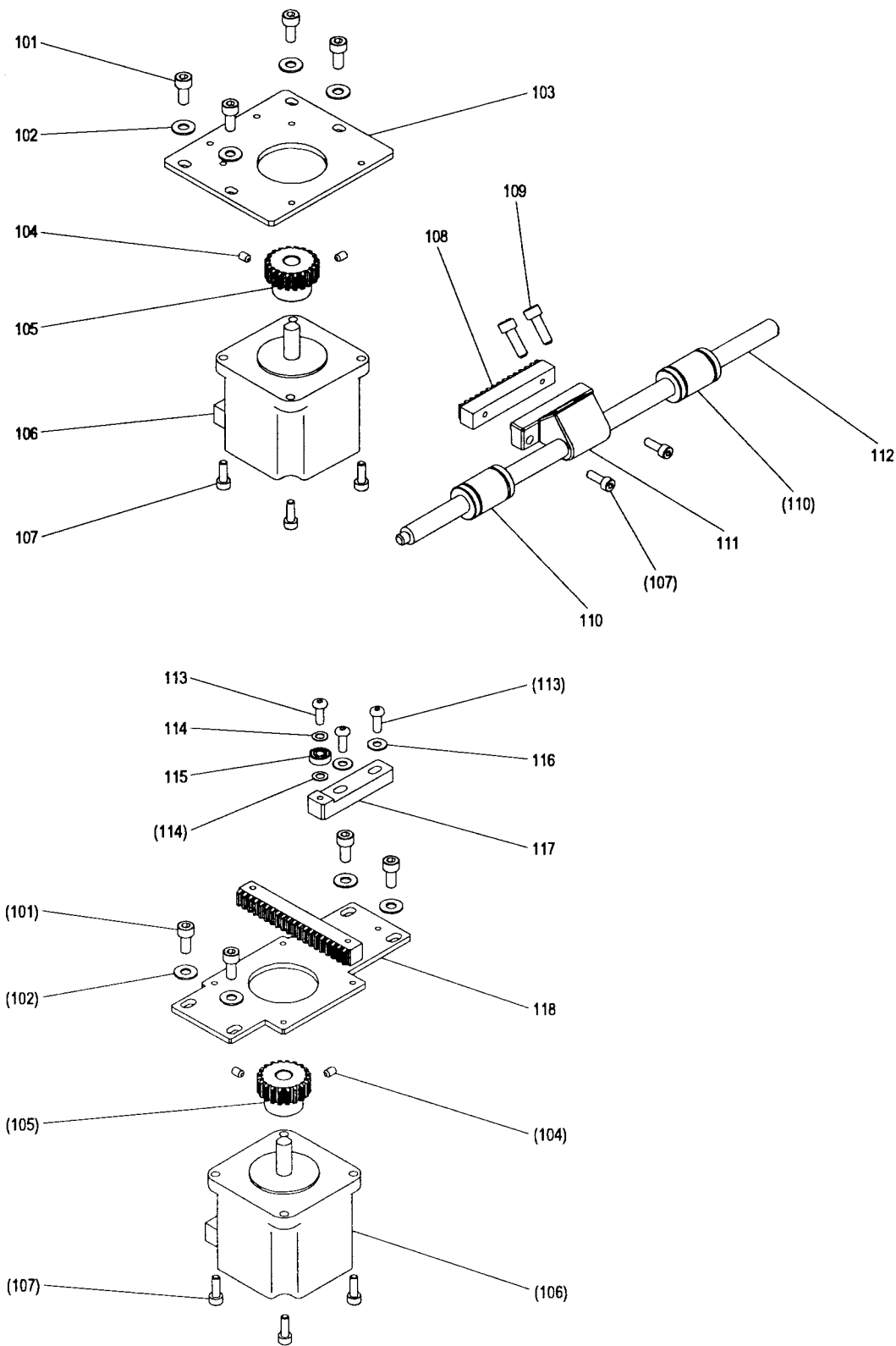

From the library of: Diamond Needle Corp

## [F] X-Yテーブル機構(1)

## X-Y TABLE MECHANISM (1)

Fig no.	変更 Mod.	部品コード Parts no.	品名	Description	数量 Amt. Req.
F 101		M95003021	ロツカクアナツキボルト M5X12	Bolt M5X12	8
F 102		M90511050	サガネ 5	Washer 5	8
F 103		ME03A0601	モ-外リツケイタ (Y)	Motor mounting plate Y	1
F 104		M95001001	ナイロツクメネジ M4X6	Screw M4X6	4
F 105		ME03A0722	ヒラハグルマ	Pinion gear	2
F 106		M95061095	ステツピングモ-タ	Stepping motor	2
F 107		M94003021	ロツカクアナツキボルト M4X12	Bolt M4X12	10
F 108		ME03A0901	ラツク (Y)	Rack Y	1
F 109		M95001021	ロツカクアナツキボルト M5X16	Bolt M5X16	2
F 110		M91003070	ボ-ルブツシュ 10	Ball bushing 10	2
F 111		ME03A1901	Yラツクダイ	Rack adapter Y	1
F 112		ME03A0390	Yクドウジク	Linear shaft Y	1
F 113		M94037021	ロツカクアナツキボ-タンボルト M4X12	Bolt M4X12	3
F 114		M90422050	サガネ 4	Washer 4	2
F 115		M92011070	ボ-ルベ-アリング	Ball bearing	1
F 116		M90421050	サガネ 4	Washer 4	2
F 117		ME03A0788	ボ-リョタイ	Bearing supporter	1
F 118		ME03A1601	モ-外リツケイタ (X)	Motor mountig plate X	1

**G** X-Yテーブル機構(2)  
X-Y TABLE MECHANISM(2)

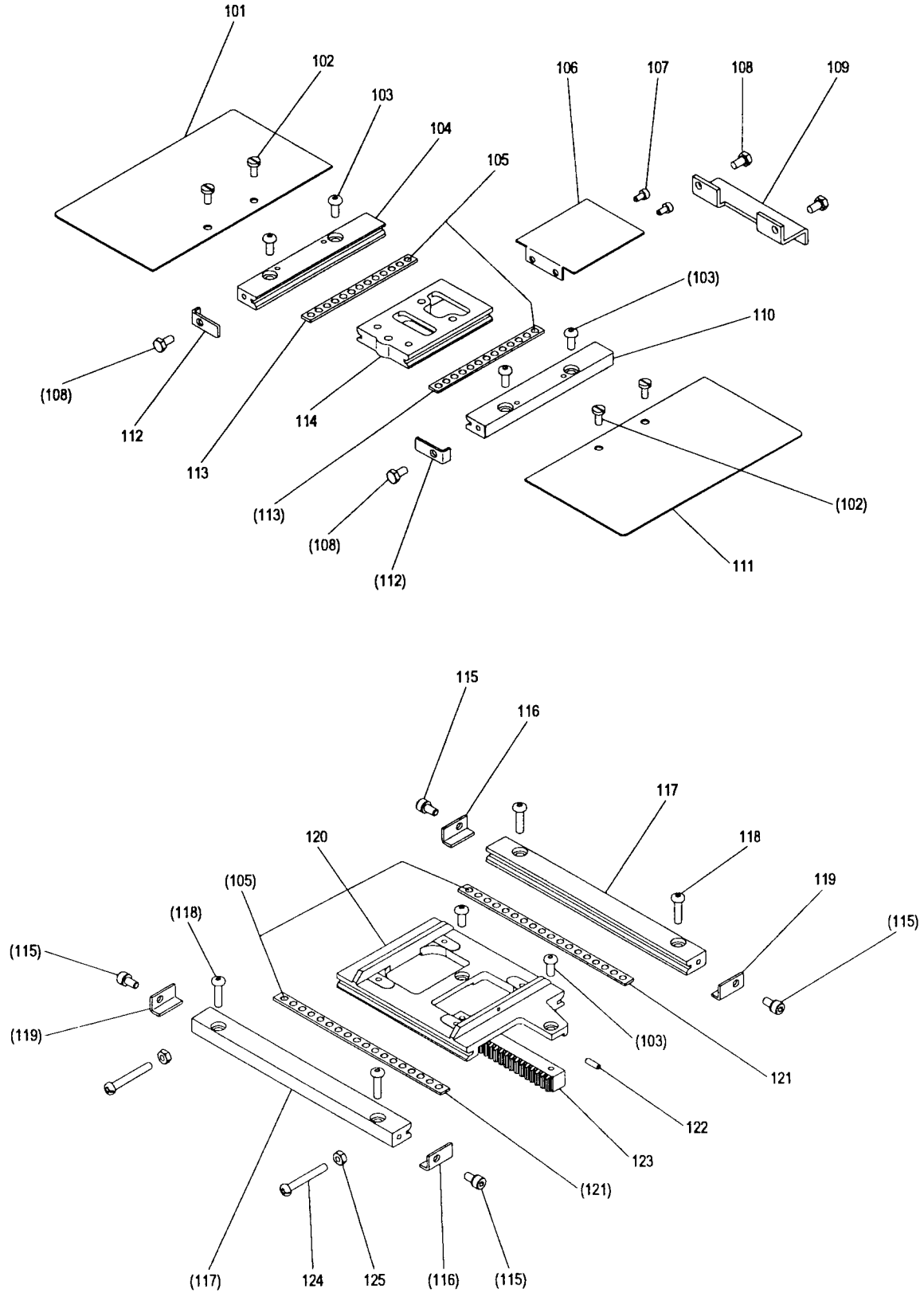

## [G]X-Yテーブル機構(2)

## X-Y TABLE MECHANISM (2)

Fig no.	変更 Mod.	部品コード Parts no.	品名	Description	数量 Amt. Req.
G 101		ME03A2339	カバー (L).....	Cover L.....	1
G 102		M90921002	ヒラネジ 9/64(40)X8.....	Screw 9/64(40)X8.....	4
G 103		M94036021	ロックアナツキボルト M4X10.....	Bolt M4X10.....	6
G 104		ME03A0957	Yジクコティレース (L).....	Fixed race Y (L).....	1
G 105		M98008070	コウキュウ 5/32.....	Steel ball 5/32.....	62
G 106		ME03A3339	Yカバーイタ.....	Cover plate Y.....	1
G 107		M93003021	ロックアナツキボルト M3X6.....	Bolt M3X6.....	2
G 108		M91003022	ロックボルト M4X8.....	Bolt M4X8.....	4
G 109		ME03A0477	Yジクストップ (ウシロ).....	Rear stopper Y.....	1
G 110		ME03A1957	Yジクコティレース (R).....	Fixed race Y (R).....	1
G 111		ME03A4339	カバー (R).....	Cover R.....	1
G 112		ME03A1477	Yストップ (マエ).....	Front stopper Y.....	2
G 113		MS08A1914	リテーナ (Y).....	Retainer Y.....	2
G 114		ME03A2957	Yジクタイトウレース.....	Movable race Y.....	1
G 115		M94002017	セフティソケット M4X8.....	Bolt M4X8.....	4
G 116		MS02A3477	ストップ X.....	Stopper X.....	2
G 117		ME03A3957	Xジクコティレース.....	Fixed race X.....	2
G 118		M94038021	ロックアナツキボルト M4X16.....	Bolt M4X16.....	4
G 119		MS02A4477	ストップ X.....	Stopper X.....	2
G 120		ME03A4957	Xジクタイトウレース.....	Movable race X.....	1
G 121		MS08A0914	リテーナ (X).....	Retainer X.....	2
G 122		M93007020	ロックアナツキメネジ M3X10.....	Screw M3X10.....	1
G 123		ME03A2901	ラック (X).....	Rack X.....	1
G 124		M90432038	プラマイナネジ M4X30.....	Screw M4X30.....	2
G 125		M91004045	ナット M4.....	Nut M4.....	2

**H** 押え上げ駆動機構  
**CLAMP FOOT LIFTER MECHANISM**

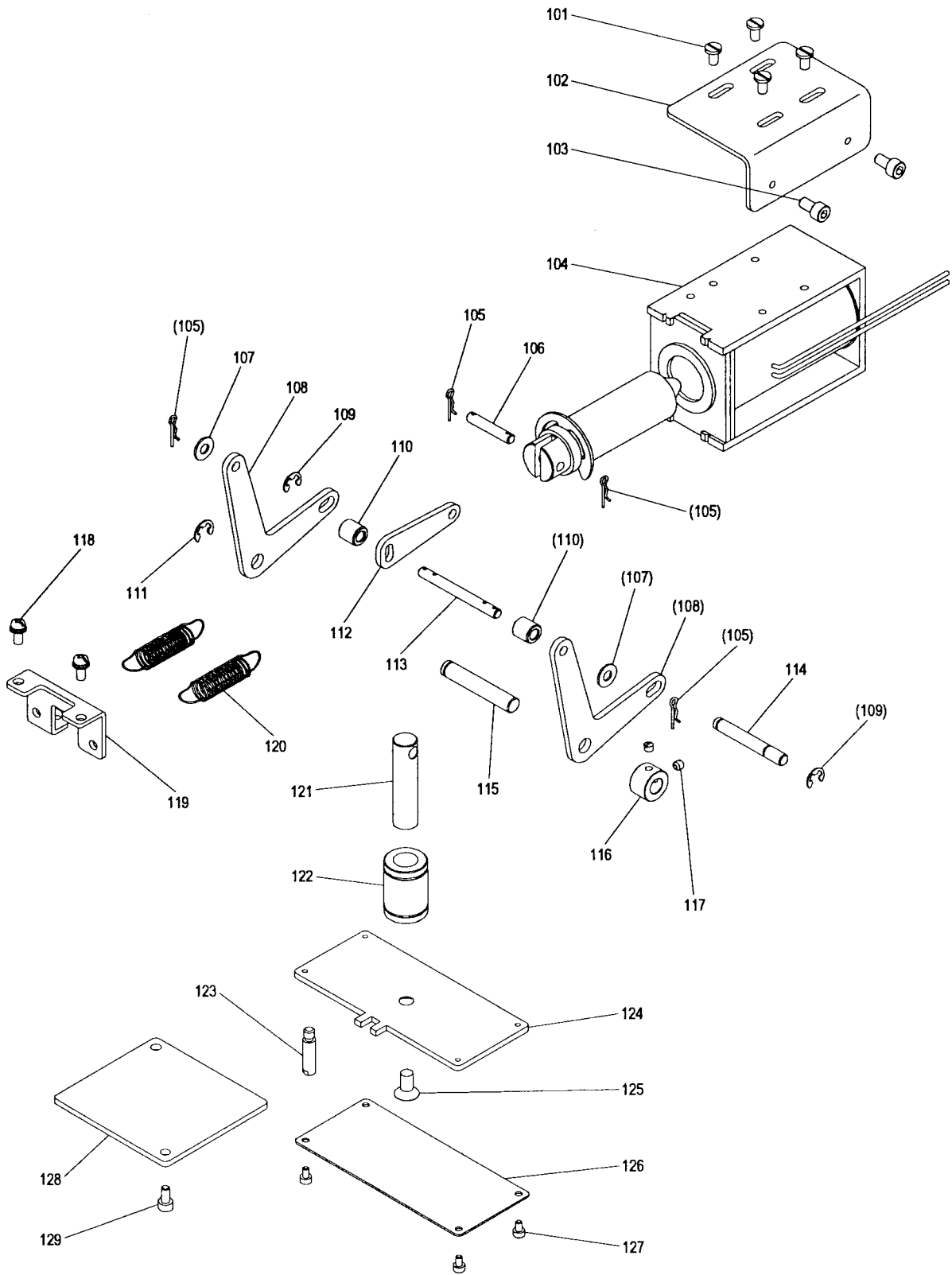

From the library of: Diamond Needle Corp



## [H] 押え上げ駆動機構

## CLAMP FOOT LIFTER MECHANISM

Fig no.	変更 Mod.	部品コード Parts no.	品名	Description	数量 Amt. Req.
H 101		M91116002	ヒラネジ 11/64(40)X8	Screw 11/64(40)X8	4
H 102		ME10A1758	ブラケット	Bracket	1
H 103		M95002021	ロックアナツキボルト M5X10	Bolt M5X10	2
H 104		ME03E2519	ソレノイドクミタテ	Solenoid assy	1
H 105		M90518060	スナップピン R5	Snap pin R5	4
H 106		M90544060	ピン A	Pin A	1
H 107		M90511050	ワッシャー 5	Washer 5	2
H 108		ME03A0266	オサエレバー	Lever	2
H 109		M90505065	E型外メ 5	E-type retaining ring 5	2
H 110		ME03A0352	カラー	Collar	2
H 111		M90511065	E型外メ 6	E-type retaining ring 6	1
H 112		ME03A0736	ヒキイタ	Link	1
H 113		M90545060	ピン B	Pin B	1
H 114		M90621060	ピン C	Pin C	1
H 115		M90707060	ピン D	Pin D	1
H 116		MG2302352	カラー	Collar	1
H 117		M91106001	トメネジ 11/64(40)	Screw 11/64(40)	2
H 118		M91056004	SW-PWプラマイナネジ M4X10	Screw M4X10	2
H 119		ME03A0780	ホルダー	Holder	1
H 120		MB60A1572	ツルマキバネ	Spring	2
H 121		ME03A0454	オサエシク	Shaft	1
H 122		M96001070	ボールブッシュ 12	Ball bushing 12	1
H 123		MB03A0802	マワリ止め	Guide pin	1
H 124		ME03A1257	オサエイタ	Pressure plate	1
H 125		M96033021	ロックアナツキサラボルト M6X12	Bolt M6X12	1
H 126		ME03A5339	カバー	Cover	1
H 127		M93004021	ロックアナツキボルト M3X5	Bolt M3X5	4
H 128		MB03A0161	アテイタ	Support plate	1
H 129		M94002017	セフティソケット M4X8	Bolt M4X8	2

**J** 押え機構  
**WORK HOLDER MECHANISM**

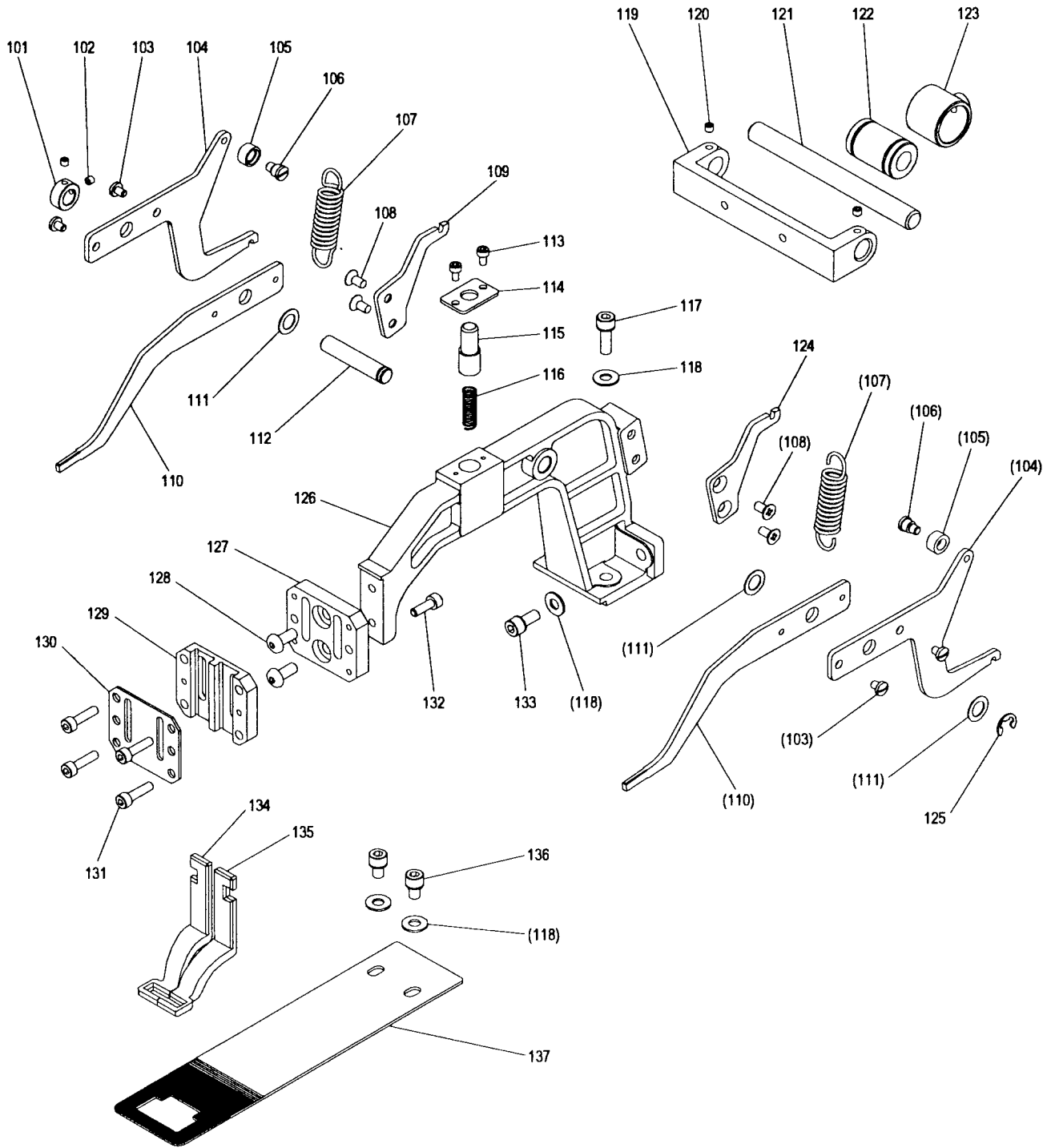

## [J] 押え機構

## WORK HOLDER MECHANISM

Fig no.	変更 Mod.	部品コード Parts no.	品名	Description	数量 Amt. Req.
J 101		MF00A1352	カラー	Collar	1
J 102		M90901020	ロックアナツキメネジ 9/64(40)X3.5	Screw 9/64(40)X3.5	2
J 103		M90943002	マルヒラネジ 9/64(40)X5	Screw 9/64(40)X5	4
J 104		ME03A0252	オサエレバー	Pressure lever	2
J 105		MN50A0411	コロ	Roller	2
J 106		M91131015	ヒラネジダンツキ 11/64(40)	Screw 11/64(40)	2
J 107		ME03A1572	ツルマキバネ	Spring	2
J 108		M91400010	Pサラネジ M4X8	Screw M4X8	4
J 109		ME03A0708	バネカケ (L)	Sping hook L	1
J 110		ME03A1252	オサエレバー M	Pressure lever M	2
J 111		M90832050	ワッシャ	Washer	3
J 112		M90821060	ピン	Pin	1
J 113		M93003021	ロックアナツキホルト M3X6	Bolt M3X6	2
J 114		ME03A0257	バネオサエイト	Hole plate	1
J 115		ME03A0457	シュウトウシ	Slider	1
J 116		ME03A0572	ツルマキバネ	Spring	1
J 117		M95004017	セフティソケット M5X16	Bolt M5X16	2
J 118		M90511050	ザガネ 5	Washer 5	6
J 119		ME03A0455	ジクササエ	Bracket	1
J 120		M91055020	ロックアナツキメネジ M4X4	Screw M4X4	2
J 121		MS08A1454	ジク	Shaft	1
J 122		M91003070	ボールブッシュ 10	Ball bushing 10	1
J 123		MS08A0692	ジクウケハウジング	Bearing housing	1
J 124		ME03A1708	バネカケ (R)	Sping hook R	1
J 125		M90511065	Eカ外メワ 6	E-type retaining ring 6	1
J 126		ME03A0308	オサエダイ	Work holder arm	1
J 127		ME03A0770	オサエアンナイベース	Work holder guide base	1
J 128		M95049021	ロックアナツキホルタンホルト M5X12	Bolt M5X12	2
J 129		ME03A0154	オサエアンナイ	Work holder guide	1
J 130		MS01A0154	オサエアンナイカバー	Cover	1
J 131		M94002021	ロックアナツキホルト M4X16	Bolt M4X16	4
J 132		M94003021	ロックアナツキホルト M4X12	Bolt M4X12	2
J 133		M95002017	セフティソケット M5X12	Bolt M5X12	2
J 134		MS01B0105	オサエ (L)	Clamp foot L	1
J 135		MS01B1105	オサエ (R)	Clamp foot R	1
J 136		M90511056	セフティソケット M5X8	Bolt M5X8	2
J 137		ME03A0272	オクリタ	Feed plate	1

**K** 糸切り機構  
**THREAD TRIMMING MECHANISM**

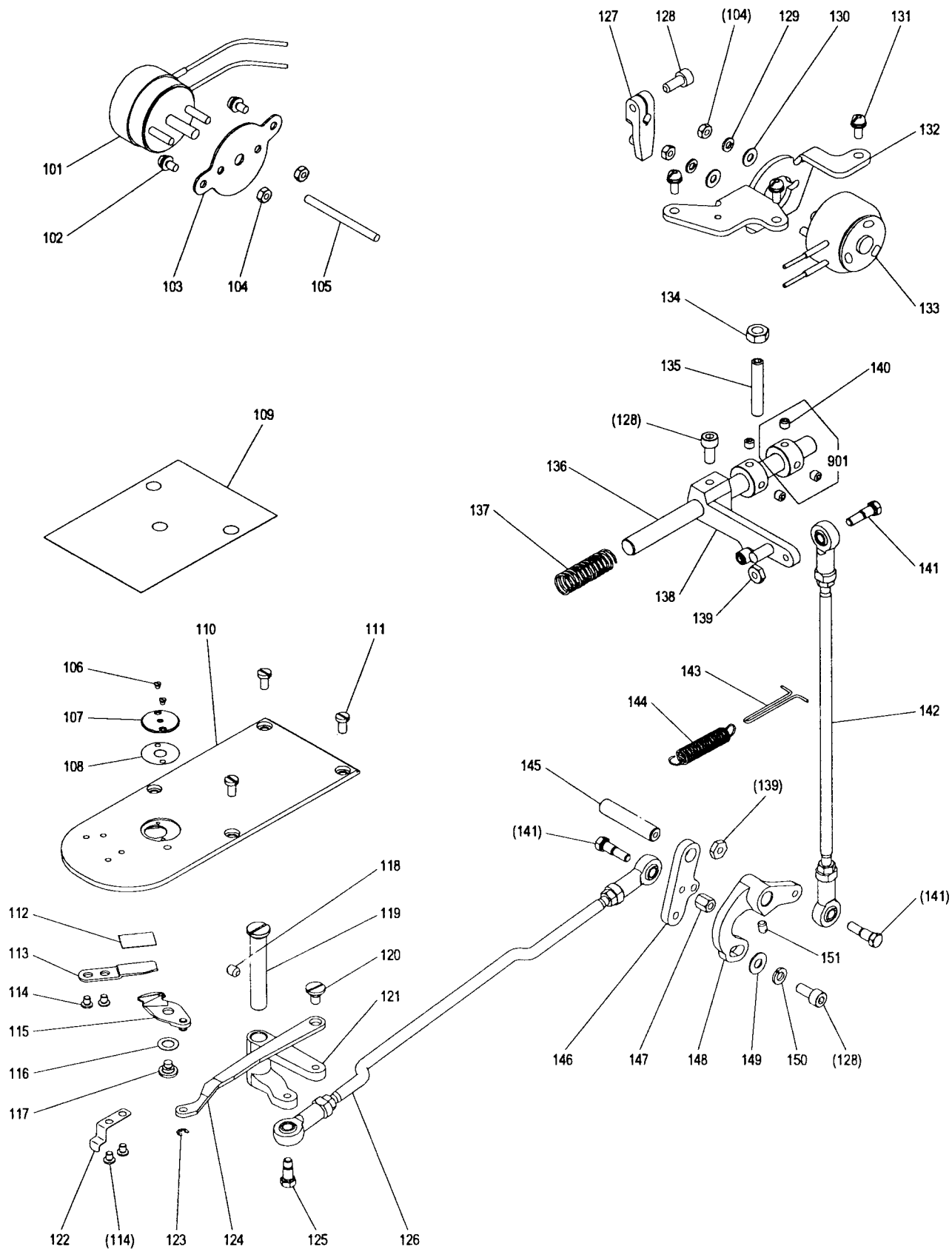

## [K]系切り機構

## THREAD TRIMMING MECHANISM

Fig no.	変更 Mod.	部品コード Parts no.	品名	Description	数量 Amt. Req.
K 101		ME03A0519	イトルメルノイト	Solenoid (thread release)	1
K 102		M91054004	SW-PWブライマイナベネジ M4X8	Screw M4X8	2
K 103		ME03A0509	ソレノイトトリツケイタ	Solenoid mounting plate	1
K 104		M91004045	ナット M4	Nut M4	2
K 105		M90430060	イトルピン	Pin	1
K 106		M90605010	サネネジ 3/32(56)X2.8	Screw 3/32(56)X2.8	2
K 107		MS03A1101	ハリイタ φ2.2	Needle plate	1
K 108		MS01A1476	スペーサー	Spacer	1
K 109		MS08A0797	ホコフィルム	Film sheet	1
K 110		MS08A0470	スベリイタ	Slide plate	1
K 111		M90990002	ヒラネジ M4X8	Screw M4X8	4
K 112		MA10B2476	スペーサー	Spacer	1
K 113		MS14A0838	コテイヌ	Fixed knife	1
K 114		M90906003	マルヒラネジ 9/64(40)X3.2	Screw 9/64(40)X3.2	4
K 115		MS03B0838	イドウメス	Movable knife	1
K 116		M96004052	ウェーブワッシャ 6	Wave washer 6	1
K 117		M91129015	ヒラネジダンツキ 11/64(40)	Screw 11/64(40)	1
K 118		M91222001	トメネジ M5X6	Screw M5X6	1
K 119		MS01A5454	ツバツキジク	Stepped pin	1
K 120		M91214015	ヒラネジダンツキ 3/16(28)	Screw 3/16(28)	1
K 121		MA20A0392	メスクトウウテ (3)	knife driving crank (3)	1
K 122		MS01A0192	イタバネ	Leaf spring	1
K 123		M90513065	Eガ外メリ 2.5	E-type retaining ring 2.5	1
K 124		MS03A1910	リンク	Link	1
K 125		M90102017	ホルトダンツキ 11/64(40)	Bolt 11/64(40)	1
K 126		ME03E0975	ロッドエンドクミタテ (ヨコ)	Connecting rod (horizontal)	1
K 127		MS01E0430	イキリサトウウテ	Crank	1
K 128		M95003021	ロツカクアナツキホルト M5X12	Bolt M5X12	3
K 129		M90424053	ハネサガネ 4	Spring washer 4	4
K 130		M90421050	サガネ 4	Washer 4	4
K 131		M91056004	SW-PWブライマイナベネジ M4X10	Screw M4X10	3
K 132		MS14A3601	ソレノイトトリツケイタ	Solenoid bracket	1
K 133		ME10E2519	イキリソレノイト	Solenoid (thread trim)	1
K 134		M91576045	ナット M6	Nut M6	1
K 135		M91652020	コネジ M6X35	Screw M6X35	1
K 136		MS01A0348	カムジク	Shaft	1
K 137		MS01A1572	ツルマキバネ	Spring	1
K 138		MS01E0351	カムツイジユウウテクミ	Cam follower assy	1
K 139		M91104045	ナット 11/64(40)	Nut 11/64(40)	2
K 140		M95004021	ロツカクアナツキトメネジ M5X5	Screw M5X5	4
K 141		M90101017	ホルトダンツキ 11/64(40)	Bolt 11/64(40)	3
K 142		MS01E0975	ロッドエンドクミタテ (タテ)	Connecting rod (vertical)	1
K 143		MS08A0708	ハネカケ	Hook	1
K 144		MS01A2572	ツルマキバネ	Spring	1
K 145		MS08A0454	ジク	Shaft	1
K 146		MS01A2392	メスクトウウテ (2)	knife driving crank (2)	1
K 147		M91109045	ロングナット 11/64(40)	Long nut 11/64(40)	1
K 148		MS01A1392	メスクトウウテ (1)	knife driving crank (1)	1
K 149		M90511050	サガネ 5	Washer 5	1
K 150		M90504053	ハネサガネ 5	Spring washer 5	1
K 151		M91108001	トメネジ 11/64(40)X5.5	Screw 11/64(40)X5.5	1
K 901		MS01A3352	カラークミ	Collar assy	2

**L** ワイパー機構  
WIPER MECHANISM

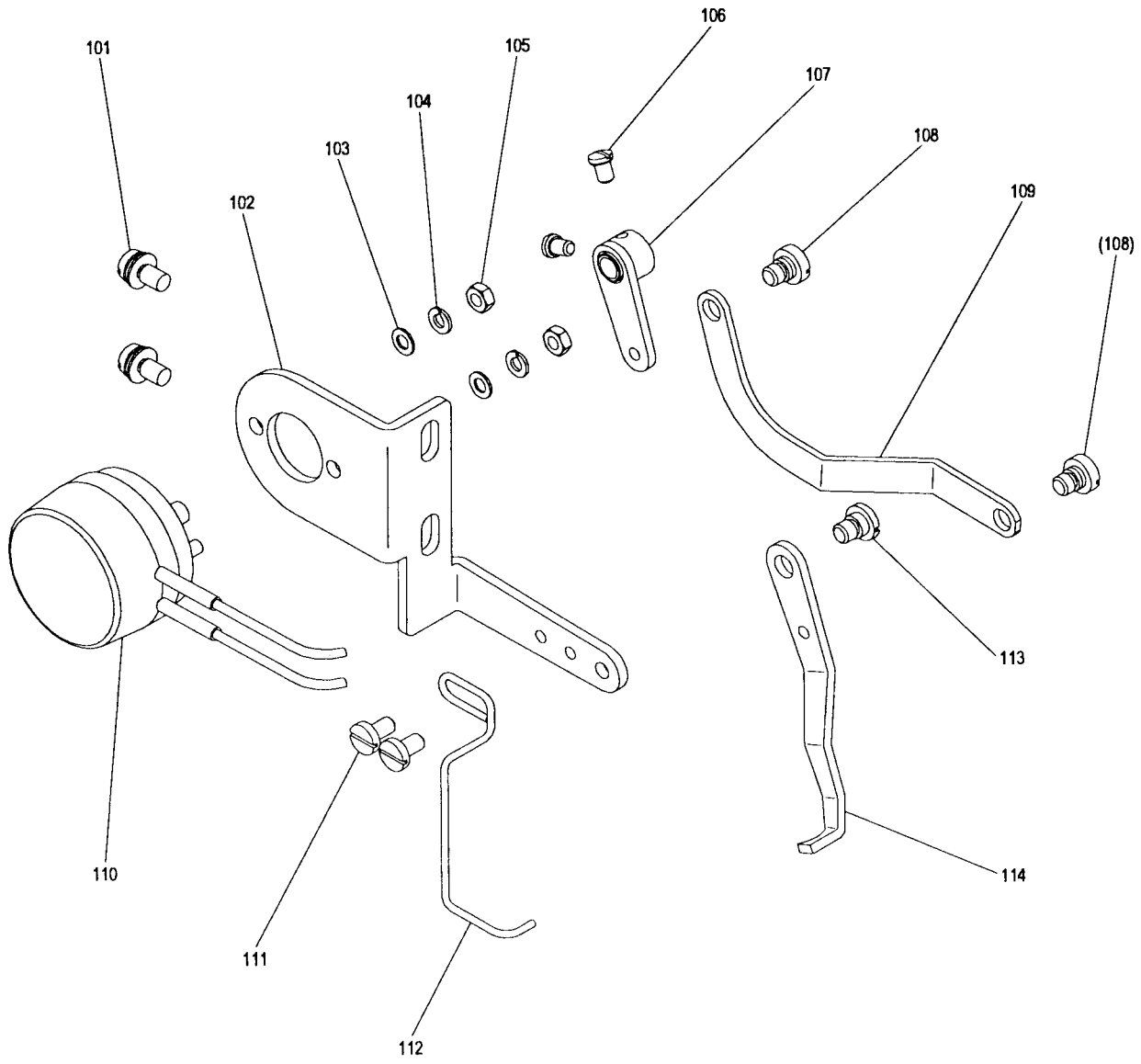

From the library of: Diamond Needle Corp

[L]ワイパー機構  
WIPER MECHANISM

Fig no.	変更 Mod.	部品コード Parts no.	品名	Description	数量 Amt. Req.
L 101		M91054004	SW-PWプライマインヘネジ M4X8	Screw M4X8	2
L 102		MB03A0601	ワイパーステ	Wiper adapter	1
L 103		M90317050	ザガネ 3	Washer 3	2
L 104		M90307053	ハネザガネ 3	Spring washer 3	2
L 105		M90875045	ナット M3	Nut M3	2
L 106		M90802003	マルヒラネジ 1/8(44)X4.5	Screw 1/8(44)X4.5	2
L 107		MB03A1950	レバ	Wiper crank	1
L 108		M90905015	ヒラネジダツキ 9/64(40)	Screw 9/64(40)	2
L 109		MB03A0910	リンク	Link	1
L 110		ME03E1519	ワイパソレノイド	Solenoid (wiper)	1
L 111		M90920002	ヒラネジ 9/64(40)X6.5	Screw 9/64(40)X6.5	2
L 112		MB03A0626	ニードルガード	Finger protector	1
L 113		M91102015	ヒラネジダツキ 11/64(40)	Screw 11/64(40)	1
L 114		MS01A0980	ワイパ	Wiper	1

**M** 給油機構  
OIL LUBRICATION MECHANISM

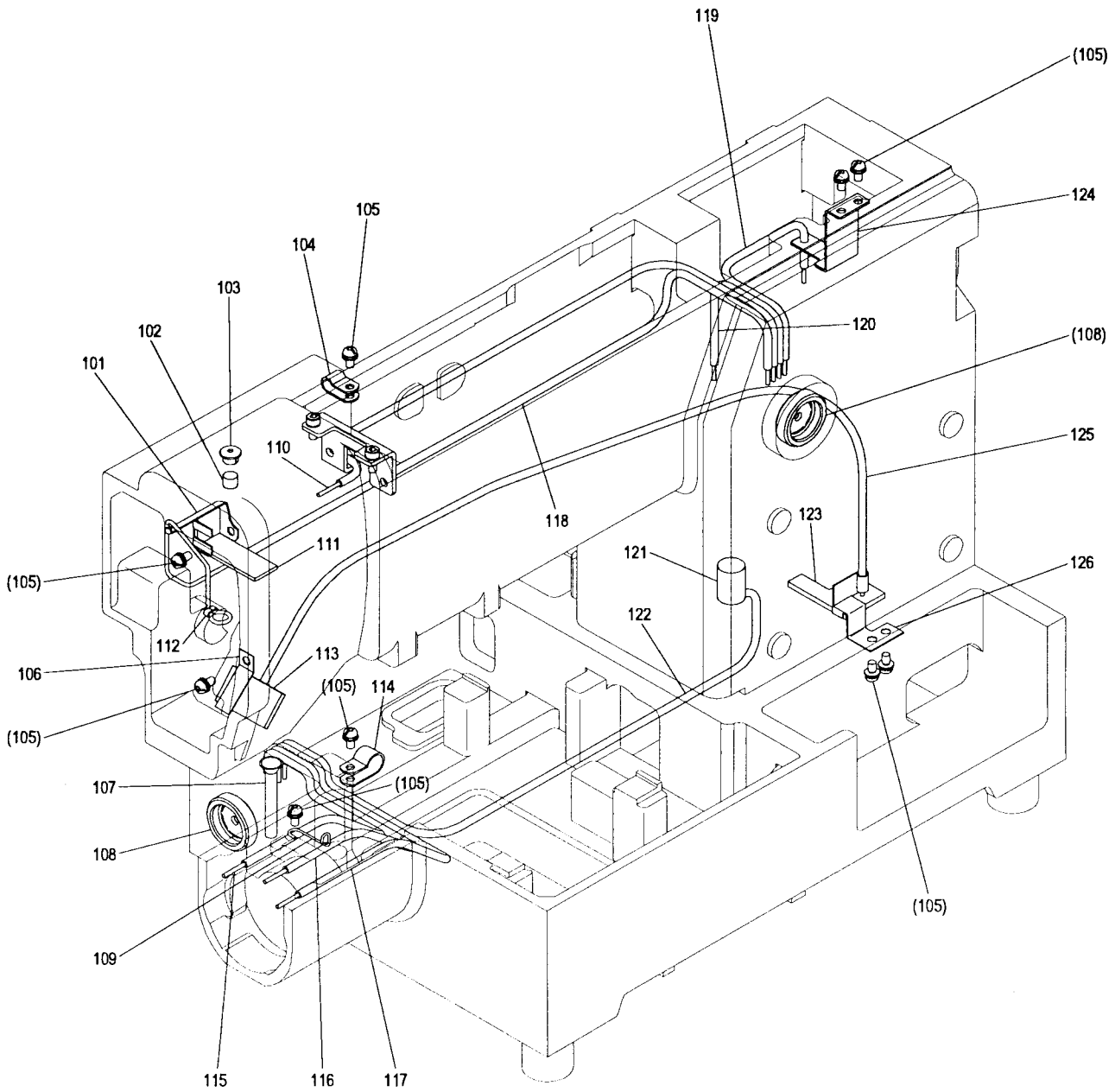



## [M] 給油機構

## OIL LUBRICATION MECHANISM

Fig no.	変更 Mod.	部品コード Parts no.	品 名	Description	数量 Amt. Req.
M 101		ME10A1780	ホルダ	Holder	1
M 102		MF10A2740	フェルト	Felt	1
M 103		MF60A0742	フタ	Cap	1
M 104		M94003099	ナイロンクリップ AB-3N	Nylon clip AB-3N	1
M 105		M91054004	SW-PWブライマイナベネジ M4X8	Screw M4X8	9
M 106		MS03A1741	ホルダ	Holder	1
M 107		MS03A0688	パイプ (アルミ)	Pipe	1
M 108		MN10A0135	オイルゲージ	Oil gauge	2
M 109		MS01A8796	ホルダ	Holder	1
M 110		ME03E0688	パイプヒモクミ (ウワジクメタル マエ)	Oil pipe assy (drive shaft bushing F)	1
M 111		MS01A1740	フェルト	Felt	1
M 112		MF80A0780	ホルダ	Holder	1
M 113		MS08A0740	フェルト	Felt	1
M 114		M94007099	ナイロンクリップ AB-6N	Nylon clip AB-6N	1
M 115		ME03E1688	パイプヒモクミ (カマ ヒタリ)	Oil pipe assy (hook left)	1
M 116		ME03E2688	パイプヒモクミ (カマ ナカ)	Oil pipe assy (hook center)	1
M 117		ME03E3688	パイプヒモクミ (カマ ミキ)	Oil pipe assy (hook right)	1
M 118		ME03E4688	パイプヒモクミ (ハリホウ)	Oil pipe assy (needle bar)	1
M 119		ME03E5688	パイプヒモクミ (レンセツカン)	Oil pipe assy (connecting rod)	1
M 120		ME03E6688	パイプヒモクミ (ウワジクメタル ナカ)	Oil pipe assy (drive shaft bushing C)	1
M 121		MF60A5740	フェルト	Felt	1
M 122		ME03E7688	パイプヒモクミ (シタジクメタル ウシロ)	Oil pipe assy (hook shaft bushing R)	1
M 123		MS14A0740	フェルト	Felt	1
M 124		MB60A1780	ホルダ	Holder	1
M 125		ME03E8688	パイプヒモクミ (カンユ)	Oil pipe assy (circulation)	1
M 126		MS01A9796	ホルダ	Holder	1

**N** 配線検出器関係  
 CABLE COMPONENT & DETECTOR MECHANISM

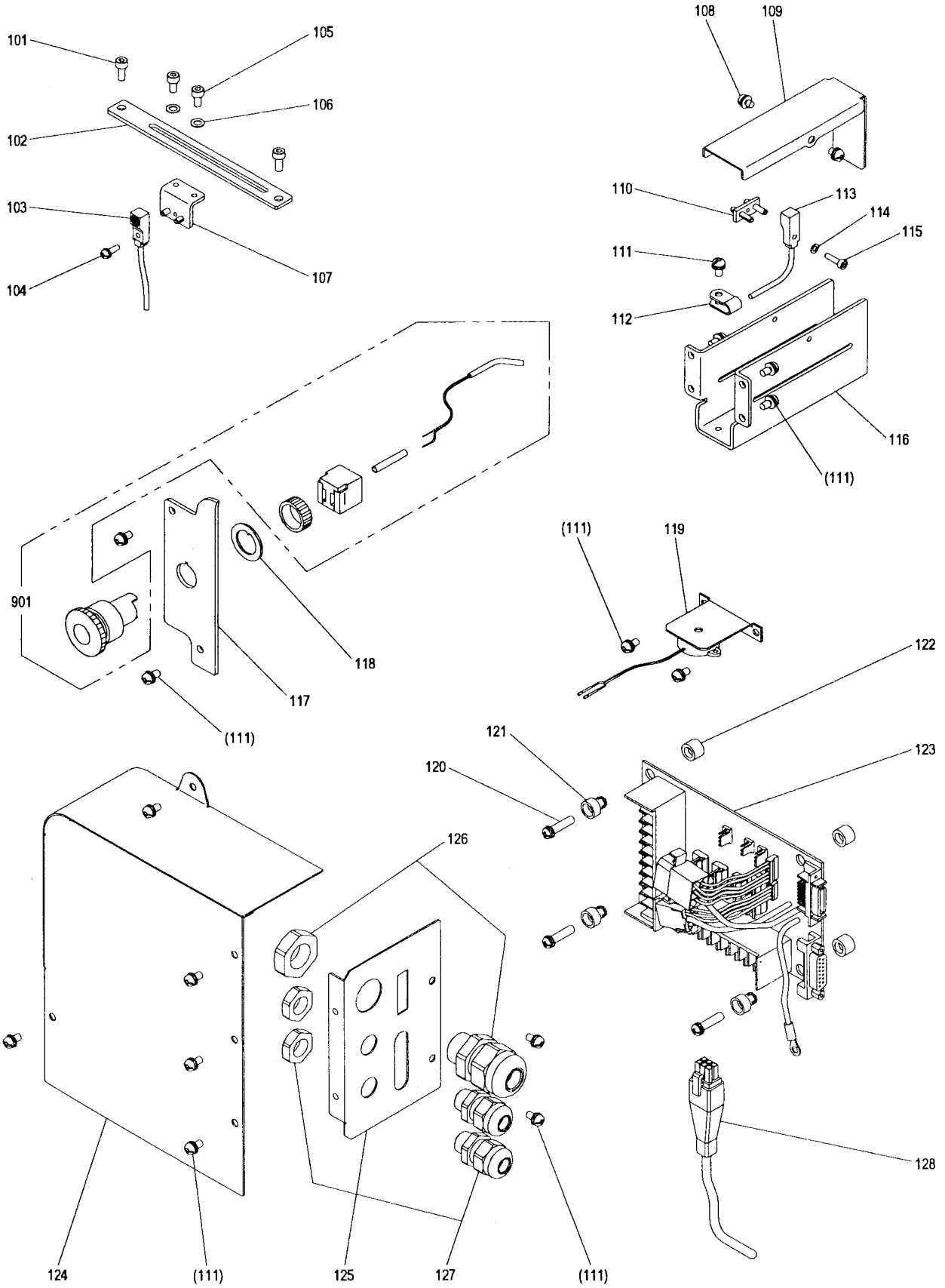

From the library of: Diamond Needle Corp

[N] 配線・検出器関係

CABLE COMPONENT & DETECTOR MECHANISM

Fig no.	変更 Mod.	部品コード Parts no.	品名	Description	数量 Amt. Req.
N 101		M91060021	ロッカアナツキホルト M4X10	Bolt M4X10	2
N 102		ME03A2601	ケンジュツキトリツケイタ X	Detector X mounting plate	1
N 103		ME03E1484	キンセツスイッチ X	Detector X	1
N 104		M90971004	SW-PWプラマイナヘネジ M3X10	Screw M3X10	1
N 105		M94001021	ロッカアナツキホルト M4X8	Bolt M4X8	2
N 106		M90422050	ザガネ 4	Washer 4	2
N 107		ME03A2408	Xケンジュツダイクミタテ	Holder plate assy X	1
N 108		M91058004	SW-PWプラマイナヘネジ M4X6	Screw M4X6	2
N 109		ME03A7339	Yケンジュツキカバー	Detector cover Y	1
N 110		ME10A2780	ネジイタクミタテ	Holder plate assy	1
N 111		M91054004	SW-PWプラマイナヘネジ M4X8	Screw M4X8	16
N 112		M94003099	ナイロンクリップ AB-3N	Nylon clip AB-3N	1
N 113		ME03E2484	キンセツスイッチ Y	Detector Y	1
N 114		M90317050	ザガネ 3	Washer 3	1
N 115		M93011021	ロッカアナツキホルト M3X12	Bolt M3X12	1
N 116		ME03A3408	Yケンジュツダイ	Detector bracket Y	1
N 117		ME03A1830	メンイタ (B)	Face cover B	1
N 118		MB60A0915	ロックリング	Lock ring	1
N 119		M93503098	ブザークミタテ	Buzzer assy	1
N 120		M91057004	SW-PWプラマイナヘネジ M4X20	Screw M4X20	4
N 121		MB60A0366	ワシタツブッシュ	Nylon bush	4
N 122		MB60A2352	ワシタツブッシュ	Nylon bush	4
N 123		M95003096	Pバンクミタテ	Print circuit board	1
N 124		ME03A6339	Pバンクカバー	Circuit board cover	1
N 125		MB60A5601	コネクタトリツケイタ	Connector panel	1
N 126		MB60A5780	コードブッシュ 大	Cord bushing (large)	1
N 127		MB60A6780	コードブッシュ 小	Cord bushing (small)	2
N 128		K14M71725402	ケーブル (エンコーダ)	Cable (Encoder)	1
N 901		ME03E0484	オンボタンスイッチクミ	Switch assy	1

P テーブル関係  
TABLE & STAND

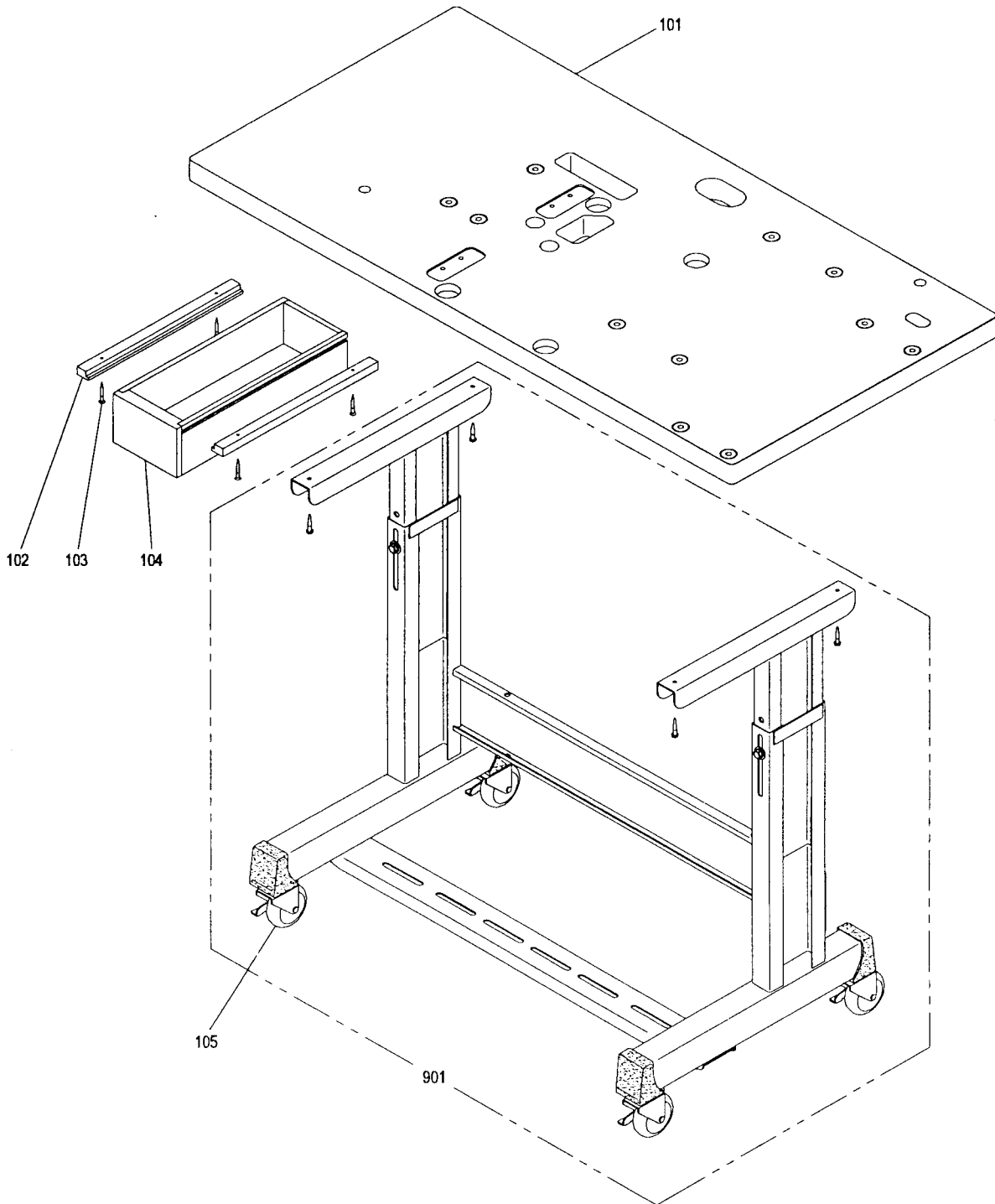

[P]テーブル関係  
TABLE & STAND

Fig no.	変更 Mod.	部品コード Parts no.	品 名	Description	数量 Amt. Req.
P 101		ME03A0595	テニタ	Table top	1
P 102		MB60A3957	レール	Rail	2
P 103		M90406040	Pサラモクネジ φ4.5X38	Wooden screw φ4.5X38	4
P 104		MB60A0719	ヒキタシ	Drawer	1
P 105		MB60A1368	キャスター	Caster	4
P 901		MB03E0150	キャクミタテ	Leg assy	1

Q 付属品(1)  
ACCESSORIES(1)

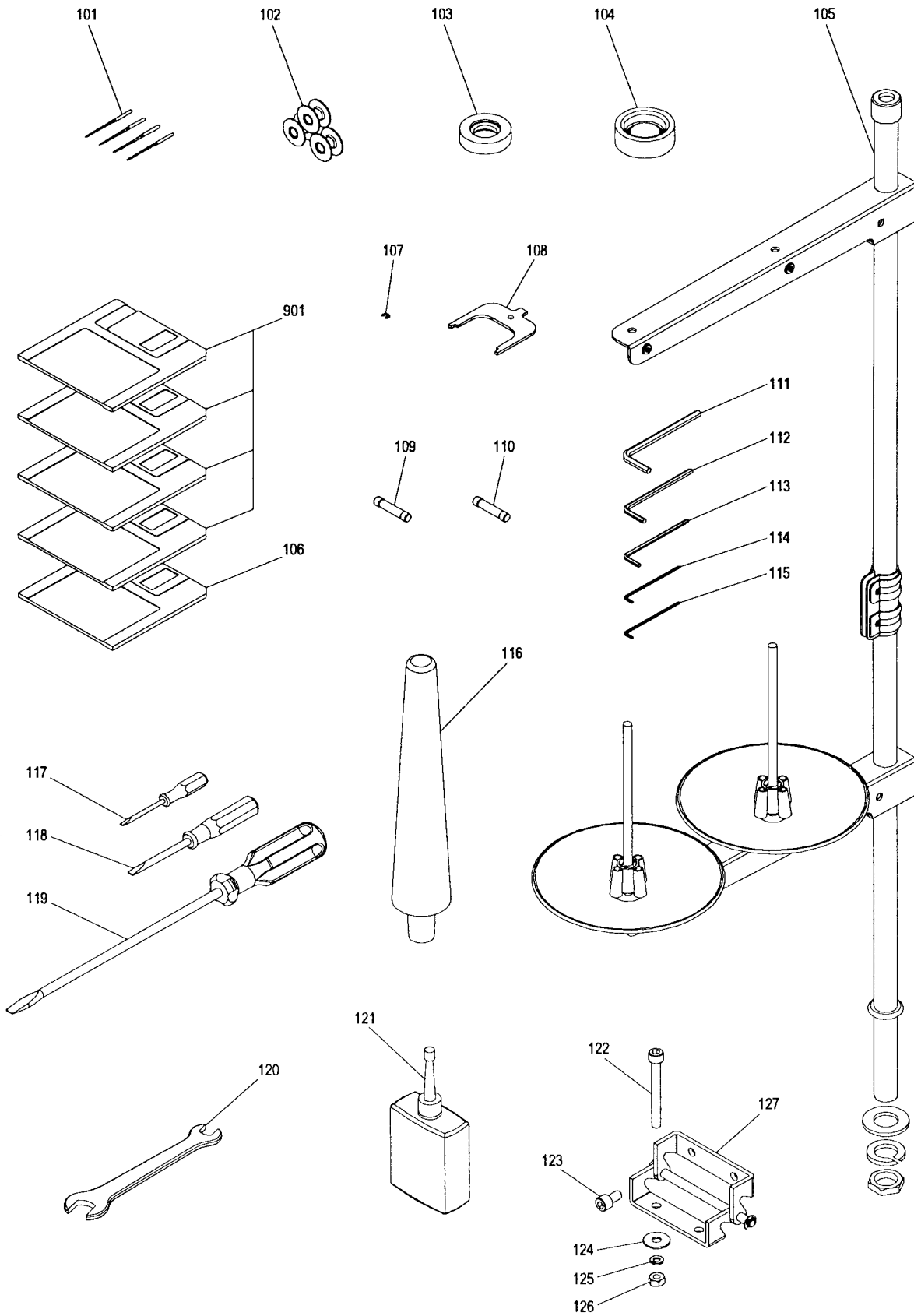

[Q] 付属品(1)  
ACCESSORIES(1)

Fig no.	変更 Mod.	部品コード Parts no.	品名	Description	数量 Amt. Req.
Q 101		MV14A1128	ミシンハリ DPX5#16	Needle DPX5#16	4
Q 102		MS09A0123	ホビン	Bobbin	3
Q 103		MS03A0417	ゴムワ (イトマキヨウ)	Tire (for bobbin winder)	1
Q 104		MB60A0419	ホウシンゴム	Rubber cushion	6
Q 105		MF33E0193	イトタテダイクミタテ	Cotton stand assy	1
Q 106		MB03A0990	パターンフロピディスク	Pattern data F/D	1
Q 107		M90513065	Eガ外メワ 2.5	E-type retaining ring 2.5	5
Q 108		MF01A0565	カドチョウセイグ	Speed command disk adjusting plate	1
Q 109		M82510FUS	ヒューズ	Fuse	2
Q 110		M95004099	ヒューズ	Fuse	2
Q 111		MS01A1976	ロッカクホウレンチ 4	Hexagonal wrench 4	1
Q 112		MB18A1479	ロッカクホウレンチ 3	Hexagonal wrench 3	1
Q 113		MB18A0479	ロッカクホウレンチ 2.5	Hexagonal wrench 2.5	1
Q 114		MS10A0976	ロッカクホウレンチ 1.5	Hexagonal wrench 1.5	1
Q 115		MN25A0479	ロッカクホウレンチ 1/16"	Hexagonal wrench 1/16"	1
Q 116		MS08A0613	トウブササエ	Head rest	1
Q 117		MF06A1608	ドライバ (ショウ)	Screw driver (small)	1
Q 118		MF06A0608	ドライバ (チュウ)	Screw driver (middle)	1
Q 119		MG33A0608	ドライバ (ダイ)	Screw driver (large)	1
Q 120		MG33A0479	スパナ 10-14	Spanner 10-14	1
Q 121		MG33A0137	アブラサシ	Oiler with oil	1
Q 122		M96020021	ロッカクアナツキボルト M6X55	Bolt M6X55	4
Q 123		M96002017	セフティソケット M6X12	Bolt M6X12	4
Q 124		M90630050	サガネ 6.5-18	Washer 6.5-18	4
Q 125		M90624053	ハネサガネ 6	Spring washer 6	4
Q 126		M91576045	ナット M6	Nut M6	4
Q 127		MB60A0560	チョウハン	Hinge	2
Q 901		ME10A0990	システムフロピディスク (4マイ)	System F/D (4discs)	1

**R** 付属品(2)  
ACCESSORIES(2)

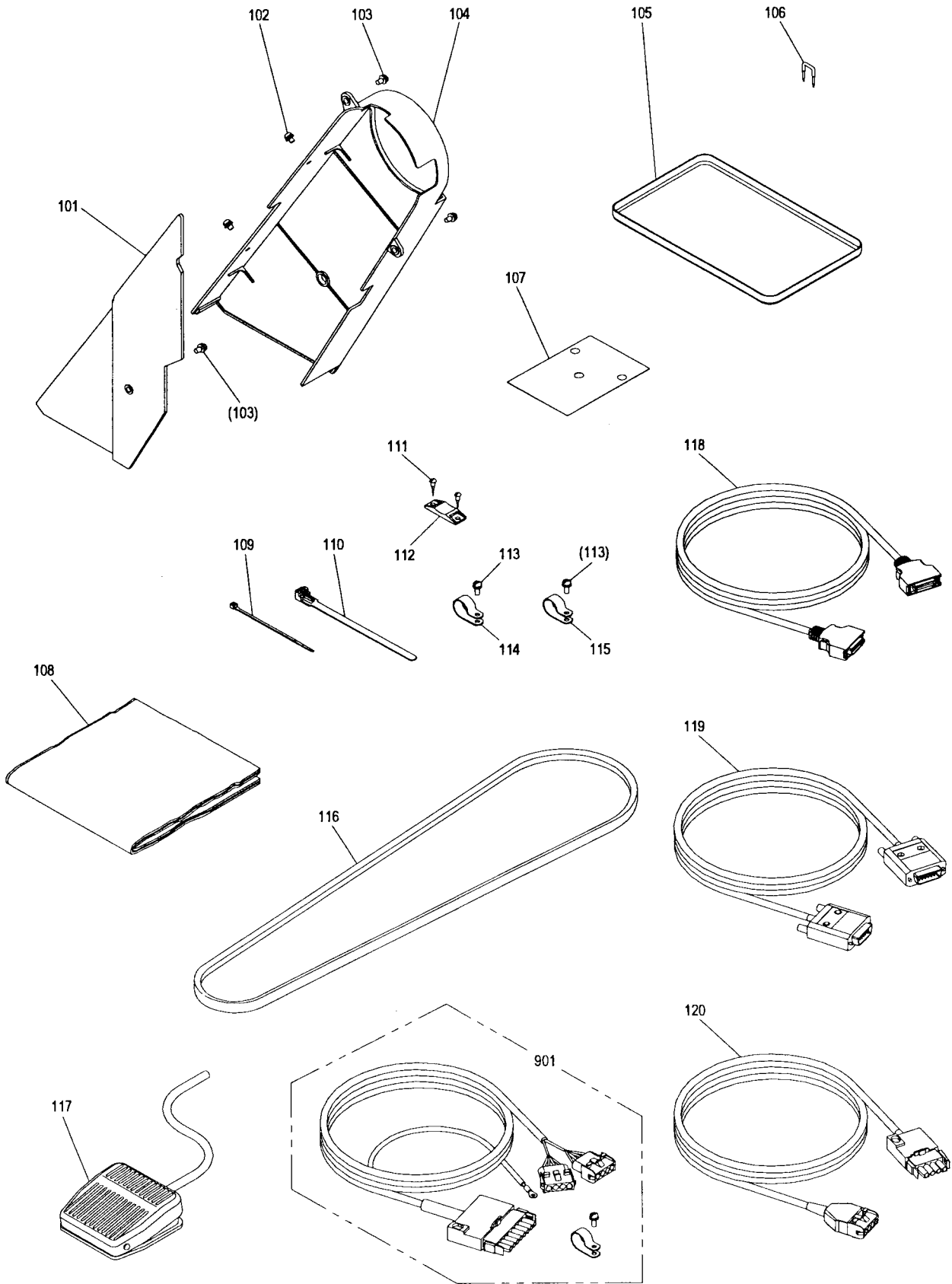



## [R] 付属品(2)

## ACCESSORIES(2)

Fig no.	変更 Mod.	部品コード Parts no.	品 名	Description	数量 Amt. Req.
R 101		ME03A0776	ベルトカバー	Belt cover	1
R 102		M91058004	SW-PWプラスマイナネジ M4X6	Screw M4X6	2
R 103		M91054004	SW-PWプラスマイナネジ M4X8	Screw M4X8	3
R 104		ME03A1776	ベルトカバー	Belt cover	1
R 105		ME03A0139	オイルパン	Oil pan	1
R 106		K14M95610701	ステッフル	Staple	4
R 107		MS08A0797	ホコフィルム	Film sheet	1
R 108		MQ10A0734	ビニルカバー	Polyethylene cover	1
R 109		MG51A0201	バインダー	Cord tie	1
R 110		MB60A0201	バインダー	Cord tie	2
R 111		M90306041	マルモクネジ 3.1X16	Wooden screw 3.1X16	4
R 112		MB60A0420	コティゲ	Tie holder	2
R 113		M91056004	SW-PWプラスマイナネジ M4X10	Screw M4X10	2
R 114		MB60A2620	ナイロンクリップ AB-10N	Nylon clip AB-10N	1
R 115		MB60A1620	ナイロンクリップ AB-8N	Nylon clip AB-8N	1
R 116		ME03A0777	Vベルト M49	V-belt M49	1
R 117		ME03AFSW	フットスイッチ	Foot switch	1
R 118		M97319099	ケーブル (ニューリョクシンコウ)	Cable (input signal)	1
R 119		M97320099	ケーブル (ソレノイド)	Cable (solenoid)	1
R 120		M97318099	ケーブル (サーボモータ用)	Cable (servo motor)	1
R 901		M97355099	ケーブル (パルスモータ)	Cable (pulse motor)	1

**S** オプションパーツ  
OPTION PARTS

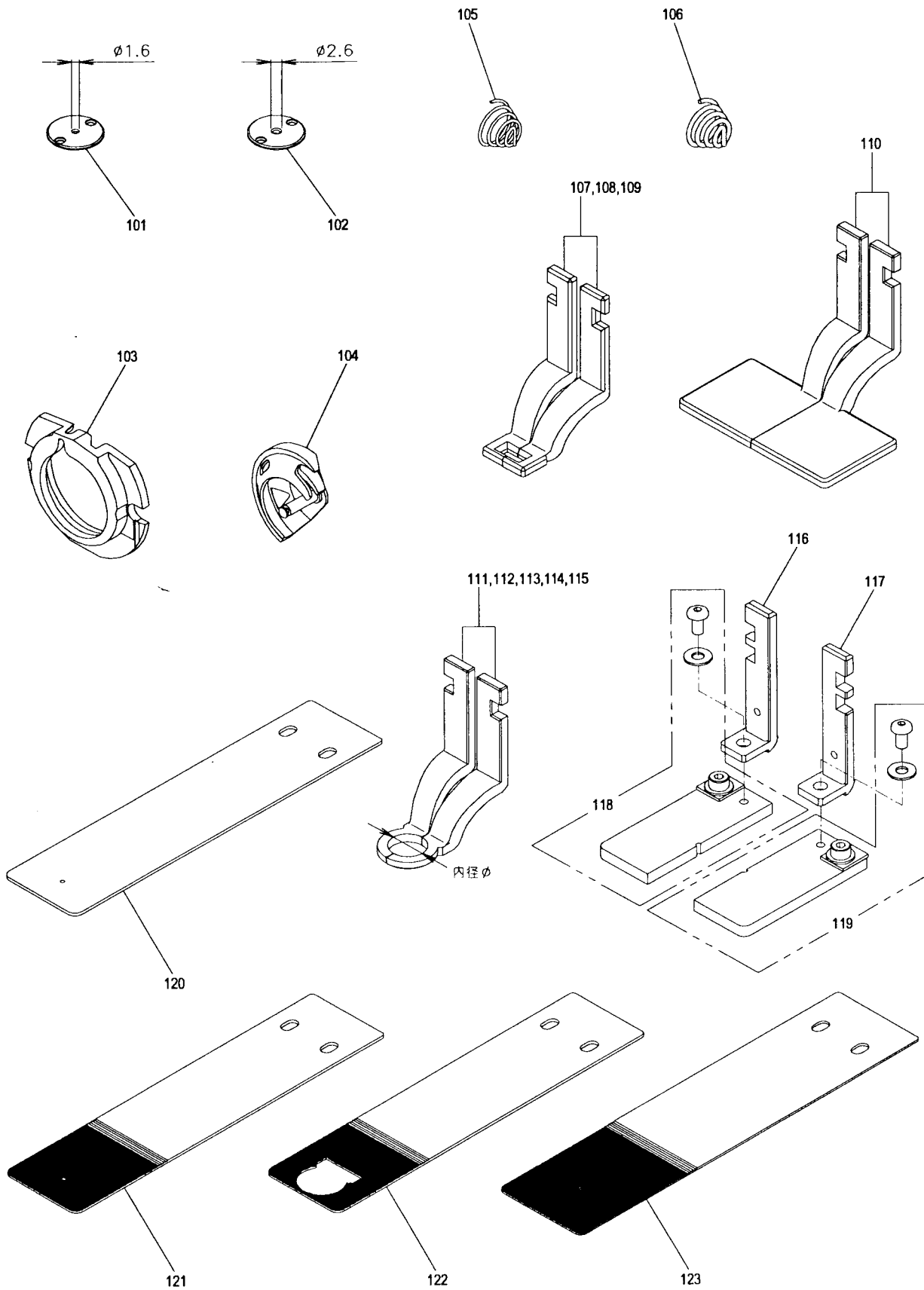

[S]オプションパーツ  
OPTION PARTS

Fig no.	変更 Mod.	部品コード Parts no.	品 名	Description	数量 Amt. Req.
S 101		MS03A0101	ハリタ (ウスモノヨウ) φ 1.6	Needle plate (for light) φ 1.6	1
S 102		MS03A2101	ハリタ (アツモノヨウ) φ 2.6	Needle plate (for heavy) φ 2.6	1
S 103		MS01A1616	ナカガマオサエ (アツモノヨウ)	Hook retain (for heavy)	1
S 104		MS01A1120	ナカガマB (アツモノヨウ)	Inner hook (for heavy)	1
S 105		MN10A3245	エンスイバネ (ジャク)	Spring (light)	1
S 106		MF23C0245	エンスイバネ (キョウ)	Spring (heavy)	1
S 107		MS08E0105	オサエ (ショウカンヨウ)	Clamp frame assy (small)	1
S 108		MS08E3105	オサエ (ダイカンヨウ)	Clamp frame assy (large)	1
S 109		MS08E1105	オサエ (メリヤスカンヨウ)	Clamp frame assy	1
S 110		MS08E2105	オサエ (カントメ・ソサイ)	Clamp frame assy (blank)	1
S 111		ME03E0105	クアナオサエ φ 11	Clamp frame assy (cap eyelet) φ 11	1
S 112		ME03E1105	クアナオサエ φ 12	Clamp frame assy (cap eyelet) φ 12	1
S 113		ME03E2105	クアナオサエ φ 13	Clamp frame assy (cap eyelet) φ 13	1
S 114		ME03E3105	クアナオサエ φ 14	Clamp frame assy (cap eyelet) φ 14	1
S 115		ME03E4105	クアナオサエ φ 15	Clamp frame assy (cap eyelet) φ 15	1
S 116		MS01A2308	オサエトリツケダイ (L)	Clamp foot L	1
S 117		MS01A1308	オサエトリツケダイ (R)	Clamp foot R	1
S 118		ME03E6105	オサエブランク L 30X30	Clamp frame blank L 30X30	1
S 119		ME03E5105	オサエブランク R 30X30	Clamp frame blank R 30X30	1
S 120		ME03A1272	オクリイタ (ソサイ・ローレットナシ)	Feed plate (blank)	1
S 121		ME03A2272	オクリイタ (ブランク)	Feed plate (blank knurling)	1
S 122		ME03A3272	オクリイタ (クアナヨウブランク)	Feed plate (cap eyelet blank)	1
S 123		ME03A4272	オクリイタブランク 30X30	Feed plate blank 30X30	1

索引  
INDEX-1

部品コード Parts No.	ページ Page	Fig No.	部品コード Parts No.	ページ Page	Fig No.	部品コード Parts No.	ページ Page	Fig No.	部品コード Parts No.	ページ Page	Fig No.
K14M71725402	... P25	... N 128	M90943002	... P17	... J 103	M91605045	... P5	... C 110	MA04A2530	... P5	... C 122
K14M95610701	... P31	... R 106	M90971004	... P25	... N 104	M91606001	... P7	... D 133	MA10B2476	... P19	... K 112
M82510FUS	... P29	... Q 109	M90990002	... P7	... D 136	M91650020	... P9	... E 114	MA16E0210	... P5	... C 901
M90001060	... P9	... E 128	↑	... P19	... K 111	M91652020	... P19	... K 135	MA20A0194	... P5	... C 127
M90101017	... P19	... K 141	M91003022	... P13	... G 108	M91802006	... P7	... D 132	MA20A0392	... P19	... K 121
M90102017	... P19	... K 125	M91003070	... P11	... F 110	M91802045	... P9	... E 105	MA20A0476	... P5	... C 118
M90204060	... P5	... C 101	↑	... P17	... J 122	M91910080	... P3	... B 110	MA20A0584	... P3	... B 121
M90306041	... P31	... R 111	M91004045	... P13	... G 125	M92011070	... P11	... F 115	MA20A0740	... P9	... E 113
M90307053	... P21	... L 104	↑	... P19	... K 104	M93001050	... P7	... D 106	MA20A1950	... P5	... C 119
M90317050	... P21	... L 103	M91004067	... P5	... C 129	M93002050	... P7	... D 102	MB03A0161	... P15	... H 128
↑	... P25	... N 114	M91005067	... P5	... C 131	M93003021	... P13	... G 107	MB03A0601	... P21	... L 102
M90330065	... P7	... D 105	M91011004	... P3	... B 124	↑	... P17	... J 113	MB03A0626	... P21	... L 112
M90406040	... P27	... P 103	M91053020	... P3	... B 122	M93004021	... P15	... H 127	MB03A0802	... P15	... H 123
M90421050	... P11	... F 116	↑	... P7	... D 120	M93006050	... P9	... E 130	MB03A0910	... P21	... L 109
↑	... P19	... K 130	M91054004	... P3	... B 103	M93007020	... P13	... G 122	MB03A0990	... P29	... Q 106
M90422050	... P11	... F 114	↑	... P5	... C 123	M93011021	... P25	... N 115	MB03A1950	... P21	... L 107
↑	... P25	... N 106	↑	... P19	... K 102	M93503098	... P25	... N 119	MB03E0150	... P27	... P 901
M90424053	... P19	... K 129	↑	... P21	... L 101	M94001021	... P25	... N 105	MB18A0479	... P29	... Q 113
M90430060	... P19	... K 105	↑	... P23	... M 105	M94002017	... P13	... G 115	MB18A1479	... P29	... Q 112
M90432038	... P13	... G 124	↑	... P25	... N 111	↑	... P15	... H 129	MB60A0201	... P31	... R 110
M90500085	... P9	... E 115	↑	... P31	... R 103	M94002021	... P17	... J 131	MB60A0366	... P25	... N 121
M90504053	... P19	... K 150	M91055020	... P5	... C 124	M94003021	... P11	... F 107	MB60A0419	... P29	... Q 104
M90505065	... P15	... H 109	↑	... P17	... J 120	↑	... P17	... J 132	MB60A0420	... P31	... R 112
M90511050	... P11	... F 102	M91056004	... P3	... B 112	M94003099	... P23	... M 104	MB60A0560	... P29	... Q 127
↑	... P15	... H 107	↑	... P15	... H 118	↑	... P25	... N 112	MB60A0694	... P7	... D 111
↑	... P17	... J 118	↑	... P19	... K 131	M94007099	... P3	... B 105	MB60A0719	... P27	... P 104
↑	... P19	... K 149	↑	... P31	... R 113	↑	... P23	... M 114	MB60A0740	... P9	... E 102
M90511056	... P17	... J 136	M91057004	... P25	... N 120	M94036021	... P13	... G 103	MB60A0915	... P25	... N 118
M90511065	... P15	... H 111	M91057020	... P5	... C 121	M94037021	... P11	... F 113	MB60A1368	... P27	... P 105
↑	... P17	... J 125	M91058004	... P25	... N 108	M94038021	... P13	... G 118	MB60A1572	... P15	... H 120
M90513065	... P19	... K 123	↑	... P31	... R 102	M95001001	... P11	... F 104	MB60A1601	... P5	... C 128
↑	... P29	... Q 107	M91060021	... P25	... N 101	M95001021	... P9	... E 123	MB60A1620	... P31	... R 115
M90518060	... P15	... H 105	M91069004	... P7	... D 103	↑	... P11	... F 109	MB60A1780	... P23	... M 124
M90544060	... P15	... H 106	M91101046	... P5	... C 139	M95002017	... P17	... J 133	MB60A2352	... P25	... N 122
M90545060	... P15	... H 113	M91102015	... P21	... L 113	M95002021	... P15	... H 103	MB60A2406	... P7	... D 101
M90601064	... P5	... C 133	M91104045	... P19	... K 139	M95003021	... P11	... F 101	MB60A2620	... P3	... B 106
M90605010	... P19	... K 106	M91106001	... P15	... H 117	↑	... P19	... K 128	↑	... P31	... R 114
M90621060	... P15	... H 114	M91108001	... P19	... K 151	M95003096	... P25	... N 123	MB60A3957	... P27	... P 102
M90624053	... P29	... Q 125	M91109045	... P19	... K 147	M95004017	... P17	... J 117	MB60A5601	... P25	... N 125
M90630050	... P29	... Q 124	M91116002	... P15	... H 101	M95004020	... P3	... B 126	MB60A5780	... P25	... N 126
M90707060	... P15	... H 115	M91129015	... P19	... K 117	M95004021	... P9	... E 107	MB60A6780	... P25	... N 127
M90802003	... P9	... E 129	M91131015	... P17	... J 106	↑	... P19	... K 140	MB60E0190	... P5	... C 903
↑	... P21	... L 106	M91180080	... P3	... B 113	M95004099	... P29	... Q 110	MB60E0234	... P7	... D 904
M90804002	... P3	... B 116	M91203002	... P9	... E 101	M95049021	... P17	... J 128	MB60E0682	... P7	... D 113
M90806002	... P3	... B 117	M91214015	... P19	... K 120	M95061095	... P11	... F 106	MB60E0950	... P5	... C 125
M90815002	... P7	... D 130	M91221001	... P7	... D 122	M96001070	... P15	... H 122	MB60E1682	... P7	... D 901
M90821060	... P17	... J 112	M91222001	... P19	... K 118	M96002017	... P29	... Q 123	MB60E1956	... P9	... E 901
M90832050	... P17	... J 111	M91223001	... P9	... E 104	M96004052	... P19	... K 116	MB60E6339	... P3	... B 133
M90853002	... P9	... E 126	M91276004	... P3	... B 101	M96020021	... P29	... Q 122	MB62A0352	... P3	... B 102
M90859004	... P3	... B 135	M91304080	... P3	... B 109	M96033021	... P15	... H 125	ME03A0139	... P31	... R 105
M90875045	... P21	... L 105	M91400010	... P3	... B 131	M97318099	... P31	... R 120	ME03A0154	... P17	... J 129
M90901002	... P5	... C 102	↑	... P17	... J 108	M97319099	... P31	... R 118	ME03A0230	... P7	... D 121
M90901020	... P17	... J 102	M91503001	... P9	... E 111	M97320099	... P31	... R 119	ME03A0252	... P17	... J 104
M90905015	... P21	... L 108	M91520002	... P7	... D 112	M97355099	... P31	... R 901	ME03A0257	... P17	... J 114
M90906003	... P3	... B 134	M91576045	... P19	... K 134	M98003015	... P9	... E 108	ME03A0266	... P15	... H 108
↑	... P19	... K 114	↑	... P29	... Q 126	M98008070	... P13	... G 105	ME03A0272	... P17	... J 137
M90920002	... P21	... L 111	M91602001	... P7	... D 118	M99006063	... P5	... C 126	ME03A0308	... P17	... J 126
M90921002	... P13	... G 102	M91602046	... P5	... C 111	MA04A1530	... P5	... C 120	ME03A0339	... P3	... B 129

索引  
INDEX-2

部品コード Parts No.	ページ Page	Fig No.	部品コード Parts No.	ページ Page	Fig No.	部品コード Parts No.	ページ Page	Fig No.	部品コード Parts No.	ページ Page	Fig No.								
ME03A0352	...	P15	...	H 110	ME03E1105	...	P33	...	S 112	MG33A0137	...	P29	...	Q 121	MS01B0105	...	P17	...	J 134
ME03A0390	...	P11	...	F 112	ME03E1484	...	P25	...	N 103	MG33A0479	...	P29	...	Q 120	MS01B1105	...	P17	...	J 135
ME03A0454	...	P15	...	H 121	ME03E1519	...	P21	...	L 110	MG33A0608	...	P29	...	Q 119	MS01E0351	...	P19	...	K 138
ME03A0455	...	P17	...	J 119	ME03E1688	...	P23	...	M 115	MG43A0181	...	P3	...	B 123	MS01E0430	...	P19	...	K 127
ME03A0457	...	P17	...	J 115	ME03E2105	...	P33	...	S 113	MG50A0740	...	P7	...	D 114	MS01E0580	...	P7	...	D 902
ME03A0477	...	P13	...	G 109	ME03E2484	...	P25	...	N 113	MG51A0201	...	P31	...	R 109	MS01E0975	...	P19	...	K 142
ME03A0509	...	P19	...	K 103	ME03E2519	...	P15	...	H 104	MG75A1476	...	P5	...	C 116	MS02A3477	...	P13	...	G 116
ME03A0519	...	P19	...	K 101	ME03E2688	...	P23	...	M 116	ML10A0889	...	P3	...	B 115	MS02A4477	...	P13	...	G 119
ME03A0572	...	P17	...	J 116	ME03E3105	...	P33	...	S 114	MM11A0245	...	P5	...	C 113	MS03A0101	...	P33	...	S 101
ME03A0595	...	P27	...	P 101	ME03E3688	...	P23	...	M 117	MM11A0352	...	P9	...	E 110	MS03A0417	...	P5	...	C 134
ME03A0600	...	P5	...	C 117	ME03E4105	...	P33	...	S 115	MM11A0556	...	P5	...	C 107	↑	...	P29	...	Q 103
ME03A0601	...	P11	...	F 103	ME03E4688	...	P23	...	M 118	MM11A0702	...	P5	...	C 112	MS03A0688	...	P23	...	M 107
ME03A0708	...	P17	...	J 109	ME03E5105	...	P33	...	S 119	MN10A0135	...	P23	...	M 108	MS03A1101	...	P19	...	K 107
ME03A0722	...	P11	...	F 105	ME03E5688	...	P23	...	M 119	MN10A1456	...	P7	...	D 104	MS03A1741	...	P23	...	M 106
ME03A0736	...	P15	...	H 112	ME03E6105	...	P33	...	S 118	MN10A3245	...	P33	...	S 105	MS03A1910	...	P19	...	K 124
ME03A0770	...	P17	...	J 127	ME03E6688	...	P23	...	M 120	MN25A0479	...	P29	...	Q 115	MS03A2101	...	P33	...	S 102
ME03A0776	...	P31	...	R 101	ME03E7688	...	P23	...	M 122	MN50A0411	...	P17	...	J 105	MS03B0838	...	P19	...	K 115
ME03A0777	...	P31	...	R 116	ME03E8688	...	P23	...	M 125	MN52A1245	...	P5	...	C 108	MS08A0125	...	P9	...	E 118
ME03A0780	...	P15	...	H 119	ME10A0148	...	P9	...	E 112	MN60A0620	...	P3	...	B 104	MS08A0160	...	P3	...	B 119
ME03A0788	...	P11	...	F 117	ME10A0742	...	P3	...	B 107	MN72A1694	...	P7	...	D 109	MS08A0454	...	P19	...	K 145
ME03A0830	...	P3	...	B 111	ME10A0990	...	P29	...	Q 901	MQ10A0734	...	P31	...	R 108	MS08A0470	...	P19	...	K 110
ME03A0849	...	P3	...	B 108	ME10A1758	...	P15	...	H 102	MS01A0120	...	P9	...	E 121	MS08A0601	...	P3	...	B 114
ME03A0901	...	P11	...	F 108	ME10A1780	...	P23	...	M 101	MS01A0121	...	P9	...	E 125	MS08A0613	...	P29	...	Q 116
ME03A0957	...	P13	...	G 104	ME10A2780	...	P25	...	N 110	MS01A0123	...	P9	...	E 119	MS08A0616	...	P9	...	E 120
ME03A1252	...	P17	...	J 110	ME10E0452	...	P9	...	E 902	MS01A0154	...	P17	...	J 130	MS08A0692	...	P17	...	J 123
ME03A1257	...	P15	...	H 124	ME10E2519	...	P19	...	K 133	MS01A0155	...	P7	...	D 134	MS08A0708	...	P19	...	K 143
ME03A1272	...	P33	...	S 120	MF00A0181	...	P5	...	C 135	MS01A0192	...	P19	...	K 122	MS08A0740	...	P23	...	M 113
ME03A1339	...	P3	...	B 130	MF00A0553	...	P5	...	C 136	MS01A0329	...	P9	...	E 127	MS08A0797	...	P19	...	K 109
ME03A1477	...	P13	...	G 112	MF00A1352	...	P17	...	J 101	MS01A0348	...	P19	...	K 136	↑	...	P31	...	R 107
ME03A1572	...	P17	...	J 107	MF00E0550	...	P5	...	C 904	MS01A0350	...	P7	...	D 124	MS08A0914	...	P13	...	G 121
ME03A1601	...	P11	...	F 118	MF01A0181	...	P7	...	D 131	MS01A0361	...	P3	...	B 132	MS08A1454	...	P17	...	J 121
ME03A1708	...	P17	...	J 124	MF01A0259	...	P7	...	D 107	MS01A0383	...	P7	...	D 905	MS08A1914	...	P13	...	G 113
ME03A1776	...	P31	...	R 104	MF01A0476	...	P7	...	D 110	MS01A0477	...	P3	...	B 120	MS08E0105	...	P33	...	S 107
ME03A1830	...	P25	...	N 117	MF01A0565	...	P29	...	Q 108	MS01A0508	...	P9	...	E 106	MS08E1105	...	P33	...	S 109
ME03A1901	...	P11	...	F 111	MF01A1476	...	P7	...	D 108	MS01A0572	...	P9	...	E 131	MS08E2105	...	P33	...	S 110
ME03A1957	...	P13	...	G 110	MF06A0608	...	P29	...	Q 118	MS01A0611	...	P9	...	E 122	MS08E3105	...	P33	...	S 108
ME03A2272	...	P33	...	S 121	MF06A1608	...	P29	...	Q 117	MS01A0660	...	P7	...	D 126	MS09A0123	...	P29	...	Q 102
ME03A2339	...	P13	...	G 101	MF10A0181	...	P3	...	B 128	MS01A0663	...	P7	...	D 125	MS09A0950	...	P9	...	E 124
ME03A2408	...	P25	...	N 107	MF10A0187	...	P5	...	C 105	MS01A0761	...	P9	...	E 116	MS10A0232	...	P7	...	D 903
ME03A2601	...	P25	...	N 102	MF10A0325	...	P7	...	D 135	MS01A0833	...	P9	...	E 103	MS10A0976	...	P29	...	Q 114
ME03A2901	...	P13	...	G 123	MF10A0553	...	P5	...	C 104	MS01A0891	...	P9	...	E 109	MS10A1740	...	P7	...	D 115
ME03A2957	...	P13	...	G 114	MF10A0555	...	P5	...	C 106	MS01A0980	...	P21	...	L 114	MS14A0180	...	P5	...	C 115
ME03A3272	...	P33	...	S 122	MF10A0709	...	P5	...	C 103	MS01A1120	...	P33	...	S 104	MS14A0350	...	P5	...	C 130
ME03A3339	...	P13	...	G 106	MF10A1555	...	P5	...	C 137	MS01A1308	...	P33	...	S 117	MS14A0553	...	P5	...	C 114
ME03A3408	...	P25	...	N 116	MF10A2740	...	P23	...	M 102	MS01A1392	...	P19	...	K 148	MS14A0572	...	P5	...	C 132
ME03A3957	...	P13	...	G 117	MF21D0181	...	P7	...	D 128	MS01A1476	...	P19	...	K 108	MS14A0682	...	P7	...	D 119
ME03A4272	...	P33	...	S 123	MF23C0245	...	P33	...	S 106	MS01A1572	...	P19	...	K 137	MS14A0740	...	P23	...	M 123
ME03A4339	...	P13	...	G 111	MF33E0193	...	P29	...	Q 105	MS01A1616	...	P33	...	S 103	MS14A0838	...	P19	...	K 113
ME03A4957	...	P13	...	G 120	MF36A0245	...	P5	...	C 138	MS01A1739	...	P3	...	B 118	MS14A3601	...	P19	...	K 132
ME03A5339	...	P15	...	H 126	MF36A1180	...	P3	...	B 125	MS01A1740	...	P23	...	M 111	MS14E0180	...	P5	...	C 902
ME03A6339	...	P25	...	N 124	MF60A0742	...	P23	...	M 103	MS01A1976	...	P29	...	Q 111	MT60A0802	...	P5	...	C 109
ME03A7339	...	P25	...	N 109	MF60A2740	...	P7	...	D 123	MS01A2308	...	P33	...	S 116	MV14A1128	...	P7	...	D 129
ME03AFSW	...	P31	...	R 117	MF60A5740	...	P23	...	M 121	MS01A2392	...	P19	...	K 146	↑	...	P29	...	Q 101
ME03E0105	...	P33	...	S 111	MF70A0352	...	P7	...	D 117	MS01A2572	...	P19	...	K 144	MV88A0740	...	P7	...	D 116
ME03E0450	...	P9	...	E 117	MF70A1180	...	P3	...	B 127	MS01A3352	...	P19	...	K 901					
ME03E0484	...	P25	...	N 901	MF80A0780	...	P23	...	M 112	MS01A5454	...	P19	...	K 119					
ME03E0688	...	P23	...	M 110	MG2302352	...	P15	...	H 116	MS01A8796	...	P23	...	M 109					
ME03E0975	...	P19	...	K 126	MG30A0664	...	P7	...	D 127	MS01A9796	...	P23	...	M 126					

 **三菱電機株式会社** 〒100-8310 東京都千代田区丸の内 2-2-3(三菱電機ビル)

お問い合わせは下記へどうぞ

F A システム事業本部 機器計画部 駆動機器グループ 〒104-6212 東京都中央区晴海 1-8-12 オフィスタワー Z 14 階  
代表電話番号 (03)6221-6160 代表 F A X 番号 (03)6221-6168

 **MITSUBISHI ELECTRIC CORPORATION**  
FACTORY AUTOMATION SYSTEM

OFFICE TOWER "Z" 14F 8-12 1chome, Harumi CHUO-KU, TOKYO 104-6212, JAPAN

Phone : +81-3-6221-6060

Fax : +81-3-6221-6076